

SAMSUNG

**Model : SR-42/43
SR-38/39**



***SERVICE* Manual**

REFRIGERATOR

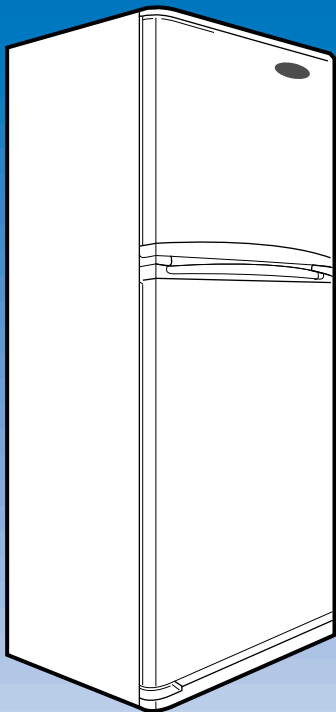

**SR-42/43
SR-38/39**



CONTENTS

1. Safety Precautions and warnings
2. Product specifications
3. Electrical part specifications & standard
4. Product dimension
5. Identifying and disassembling the parts
6. Schematic diagram of coolant gas circulation
7. Circuit diagram
8. Packing dimension
9. Schematic diagram of cold air flow
10. Troubleshooting method
11. Exploded view & part list
12. How to disassemble of freezing compartment
13. How to disassemble of refrigerating compartment







1. Safety precautions and warnings

Read all instructions before using this appliance in order to avoid risk of accident or possible damage.







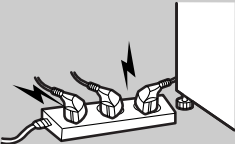

Warning/Caution

	Warning	This symbol is intended to alert the user to the possible death or injury.
	Caution	This symbol is intended to alert the user to the possible injury or damage.

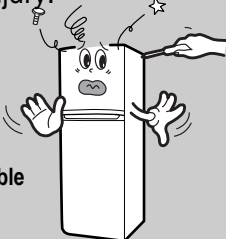
Description of symbols

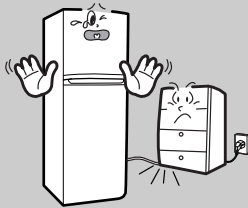
	Indicates prohibition
	Do not disassemble
	Do not contact
	Adhere the instruction strictly
	Unplug from the electrical outlet
	Earth the appliance to avoid the risk of an electric shock

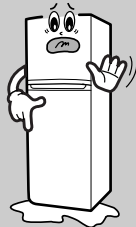
Warning

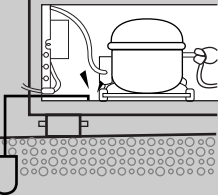
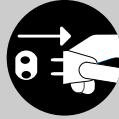
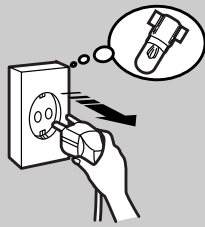
<p>Do not plug multiple electrical appliances into the same outlet.</p> <ul style="list-style-type: none"> This may cause abnormal heating or a fire hazard. <p style="text-align: center;"></p> <p style="text-align: center;">Prohibition</p> 	<p>Do not attempt to make repairs yourself.</p> <ul style="list-style-type: none"> This could lead to fire hazard or abnormal operation causing severe personal injury. <p style="text-align: center;"></p> <p style="text-align: center;">Do not disassemble</p> 	<p>Make sure the power cord is not crushed or damaged.</p> <ul style="list-style-type: none"> Repair immediately all power cords or outlets that have become frayed or otherwise damaged. <p style="text-align: center;"></p> 
<p>Check the operating environment.</p> <ul style="list-style-type: none"> Do not install the refrigerator in a humid (with condensation) location or on an unstable surface. <p style="text-align: center;"></p> 	<p>Do not attempt to make repairs yourself.</p> <ul style="list-style-type: none"> This could lead to fire hazard or abnormal operation causing severe personal injury. <p style="text-align: center;"></p> <p style="text-align: center;">Earth</p> 	<p>Make sure the power cord is not crushed or damaged.</p> <ul style="list-style-type: none"> Repair immediately all power cords or outlets that have become frayed or otherwise damaged. <p style="text-align: center;"></p> <p style="text-align: center;">Unplug</p> 



Caution

Do not store bottled food or drinks in the freezing compartment.

- Bottles may explode causing personal injury.



Prohibition



Do not store food in an unstable manner.

- Opening the door may trigger loose items to slip and cause injury.



Prohibition



Do not store anything other than food in the refrigerator.

- Medical supplies which need to be under strict temperature control should not be stored in the refrigerator.



Prohibition



Do not put anything on top of the refrigerator.

- Opening or closing the door may trigger loose items to slip and cause injury.



Prohibition



When replacing electric components, be sure to use rated components.

- Check the model, rated voltage, rated current, operating temperature etc. of the component.

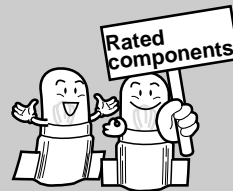

When servicing the refrigerator, completely remove dust or foreign substances from the housing, electric connections and etc.

- This can protect against the risk of fire hazard caused by tracking and short circuit



When servicing the refrigerator, completely remove dust or foreign substances from the housing, electric connections and etc.

- This can protect against the risk of fire hazard caused by tracking and short circuit.

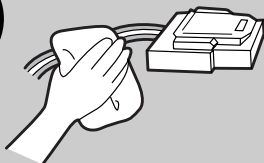

After servicing the refrigerator, be sure to check the components are reassembled in a correct manner.

- The serviced unit should be reassembled and returned to its original assembly state.



Check the electrical parts for the trace of moisture penetration.

- When the trace of moisture penetration is detected, replace the part or try insulation taping.

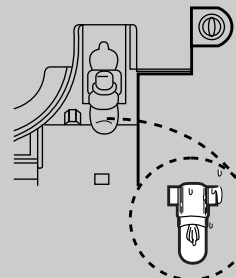

3. Electrical part specifications & standard

[CFC-FREE]

ITEM		STANDARD				
Model		SR-38/39		SR-42/43		
Power source		110V/60Hz	127V/60Hz	220V/50,60Hz	230,240V/50Hz	
Refrigeration Cycle	Compressor	Model	SD162C-L1W2	SD162P-L1W2	SD162H-L1U2	SD162Q-L1U2
		Starting type	C.S.R		R.S.C.R	
		Oil charge	FREOL -15c / 200cc			
	Evaporator		Split fin type			
	Condenser		Forced & natural convection			
	Dryer		Molecular sieve			
	Capillary tube		I.D 0.75 x L3400 (mm)			
Electrical	Thermostat	Freezer	PFN - C174S-03C			
		Refrigerator	D-705-E8			
	Defrost-thermo	Bimetal (OFF/ON)	Type	AC 250V / 5A		
			Oper. temp.	ON : -5 ±3°C / OFF : 12±3°C		
		Thermal fuse	Regularity	AC 250V / 10A		
			Oper. temp.	72±4°C		
	Defrost-timer	Type	TMDE714F1	TMDE714A1		
		Cycle	6hr 35min			
		Time	13min 40s			
	Starting-relay	Model	PTHAS-T100M200B		PTHAS-T330M385D	
		Resistance	10 ±20%		33 ±20%	
	Overload protector	Model	4TM427	4TM317	4TM265	4TM222
			PHBYY-53	RHBYY-53	RHBYY-53	PHBYY-53
			Close temp.	69±9°C		
		Open temp.	125±5°C	130±5°C	125±5°C	
	Motor-fan	Cooling	AMRHB-010ZQRB		AMRHB-010WTEB	
	Capacitor	Running	8µF/250VAC		3.5µF/350VAC	
Starting		100µF/250VAC		-		
Motor-gearred		M2BC18AR02		M2LC18AR02		
Heater-defrost		130W/93	130W/124	130W/372	130W/443	
Lamp		110V/15w	127V/15W	220V/15W	240V/15W	
Door-Switch		250V/0.5A				
Earth screw		BSBN(Brass screw)				

2. Product Specifications

ITEM		STANDARD	
Model name		SR-38/39	SR-42/43
Type		2-Door Freezer/Refrigerator	
Power source		AC 110V/60Hz, 127V/60Hz, 220V/50~60Hz, 240V/50Hz	
Net capacity (<i>l</i> / cu.ft)	Freezer	99(3.5)	99(3.5)
	Refrigerator	225(7.9)	261(9.2)
	Total	324(11.4)	360(12.7)
Net dimension (<i>mm</i>)	Width	670	
	Depth	650	
	Height	1682	1759
Net weight (kg)		67	70
Refrigerant		R-134a(150gr)	
Temperature control		Dial(Thermostat)	
Defrosting		Automatic(Start-Finish by Timer)	
Foam insulation	Cabinet	Cyclo-pentane	
	Door	Cyclo-pentane	
Liner / Door panel		ABS(SD-0150)	
Accessory parts	Door storage	3 Guard-freezer 1 Guard-egg 1 Guard-variety 1 Guard-jumbo	
	Inside storage	1 Base-tray ice 1 Case-tray ice, assy 1 Tray-ice cube 1 Shelf-freezer 1 Tray-chilled room(H,M,G) 1 Cover-chilled room(H,M,G)	
		1 Tray-vegetables 1 Cover-vegetable 2 Shelf-refrigerator 1 Shelf-chilled (L,) 1 Shelf-chilled ,wire(N) 1 Shelf-ref wire (L,G, N) 2 Shelf-ref wire (G, N)	
	Interior lamp(H/M)	2 (Refrigerator) / 1 (Refrigerator)	
	Movable caster	2 (Rear)	
	Angle adjustment	2 Legs (Front)	

4. Product Dimension

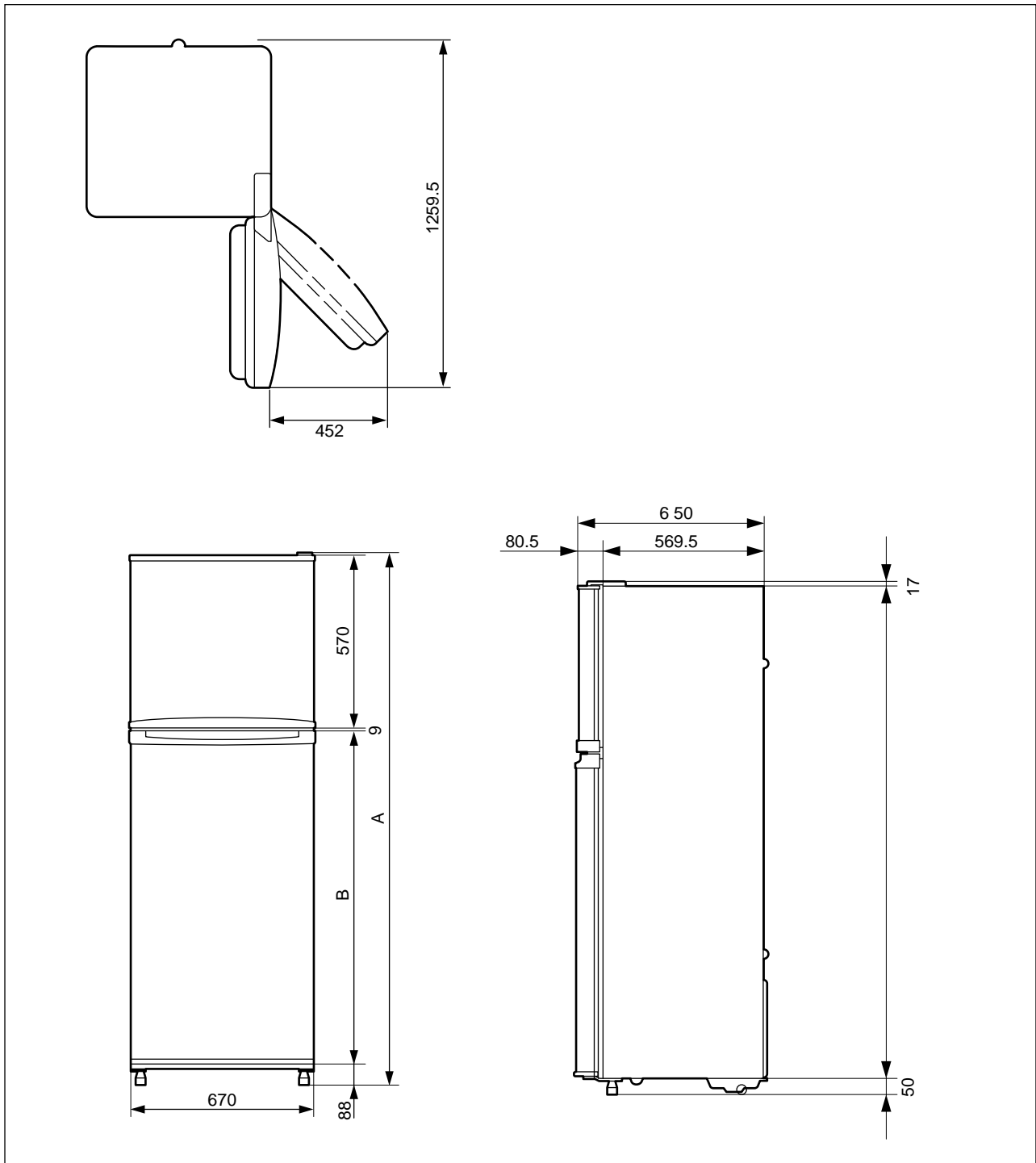

MODEL	A	B	Remark
SR-42/43	1759	1078	
SR-38/39	1682	1001	

5. Identifying and disassembling the parts

To remove shelves in the freezing compartment

- First remove the icemaking molds. Tilt the shell up at front, then lift it up pull it out of the tracks.

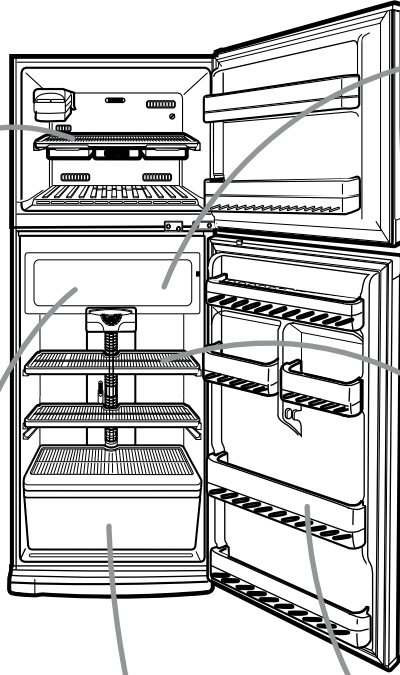
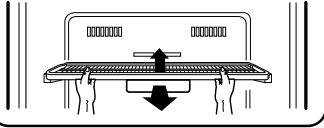

To remove bio deodorizer

- While pushing the front end knob of the bio deodorizer, pull it downward to disengage.

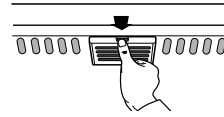

To remove shelves in the refrigerating compartment

- Hold the shelf by the front and pull it forward of the rack.

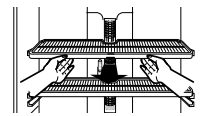

To remove shelves in the chilled compartment

- Lift up the cover, push the cover to the right (as shown) until the mounting hook (1) disengages, then disengage the other mounting hook (2) and pull out the cover.
- Pull the shelf forward until it stops. then lift it up and pull it out.

Disassemble

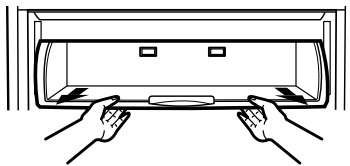
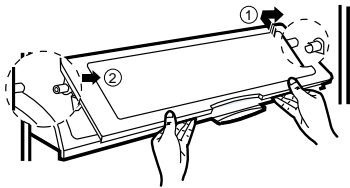

Reassemble

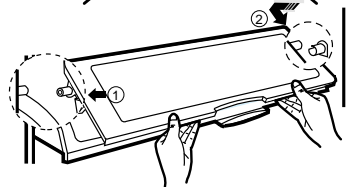
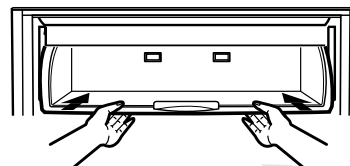

- With shelf front raised slightly, engage, the roller between the rails and slide it back.
- To replace the cover, first engage the mounting hook (1) as shown, then engage the other hook (2) and push in.

To remove door bins

- While pushing the bin to the left, lift it up to disengage.

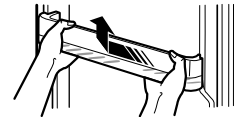

To remove storage drawers and covers

- Lift up to remove the cover. Pull the drawer half way out, then lifting it up, pull it out completely.

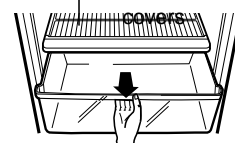

6. Schematic diagram of coolant gas circulation

COMPRESSOR --> CLUSTER PIPE --> HOT PIPE --> DRYER --> CAPILLARY TUBE --> EVAPORATOR --> ACCUMULATOR --> SUCTION PIPE --> COMPRESSOR

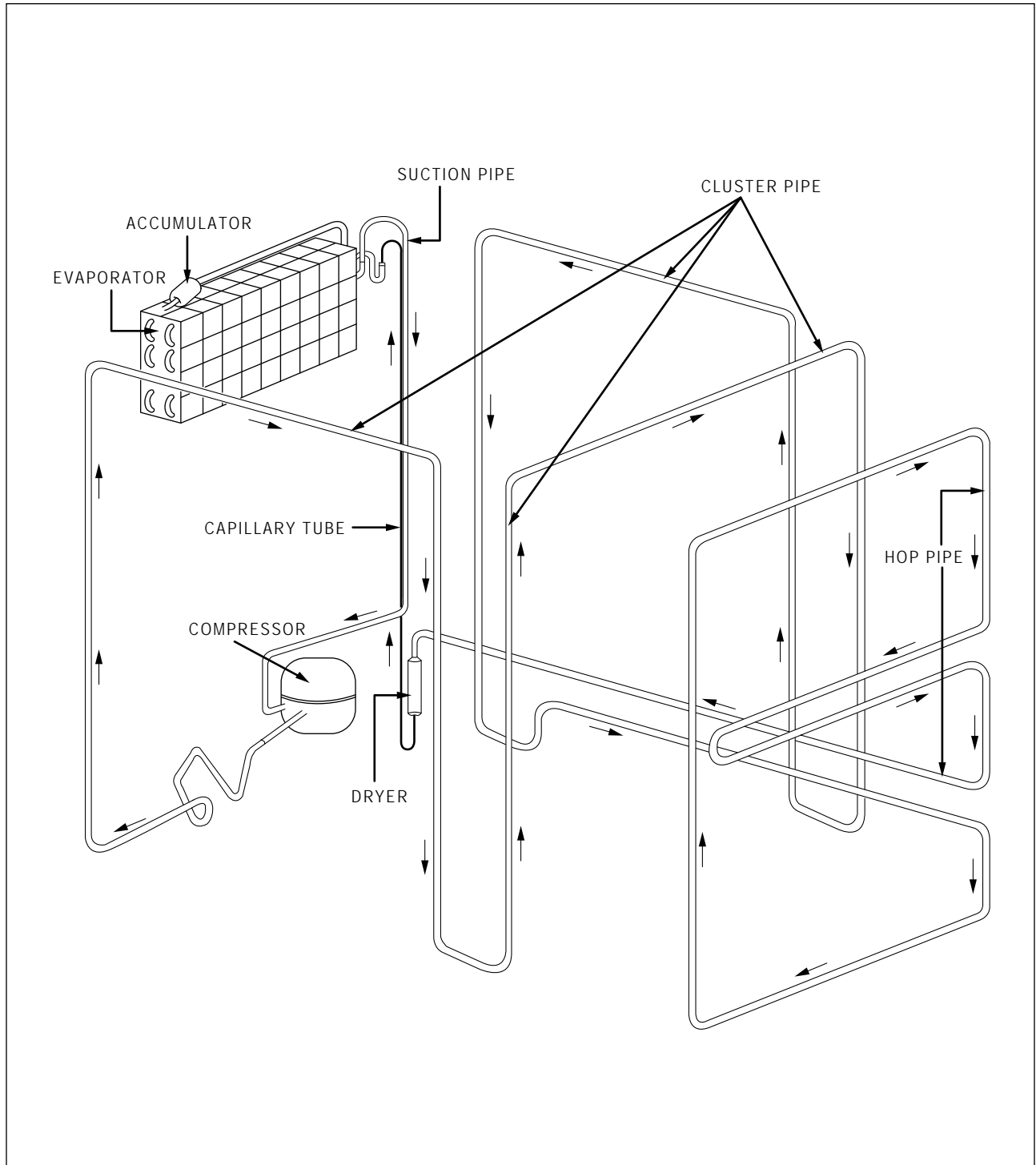

7. Circuit diagram

7-1 [220V/50, 60Hz, 230~240V/50Hz] SR-42/43,SR-38/39

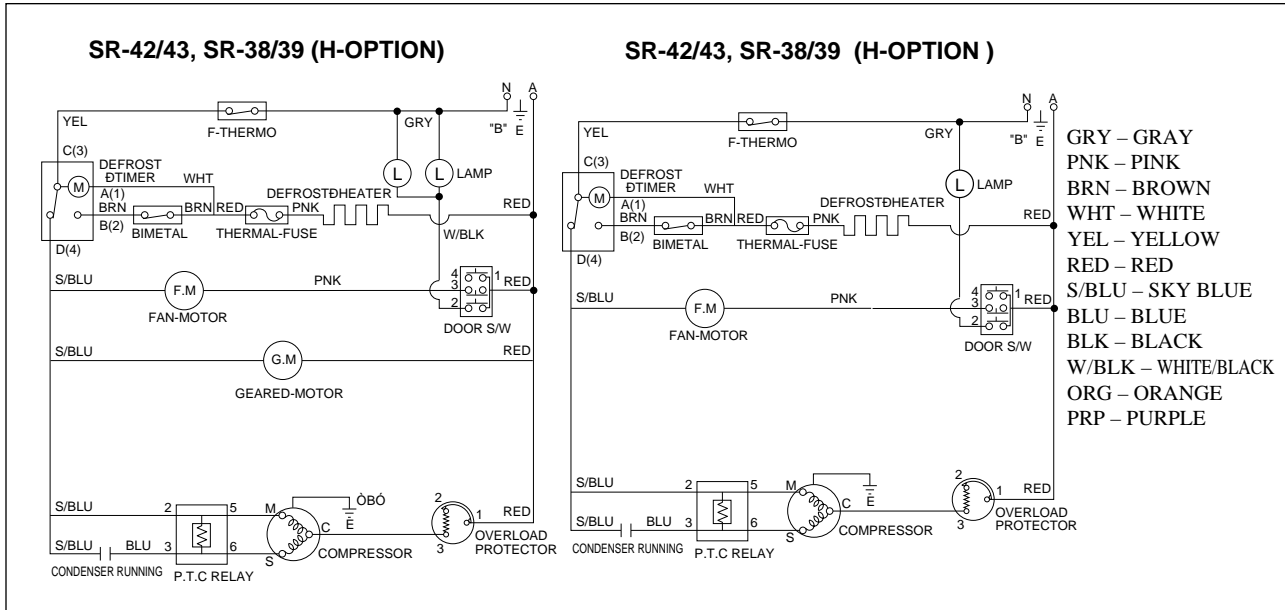

7-2 [110V/ 60Hz, 115V/60Hz, 127V/60Hz] SR-42/43,SR-38/39

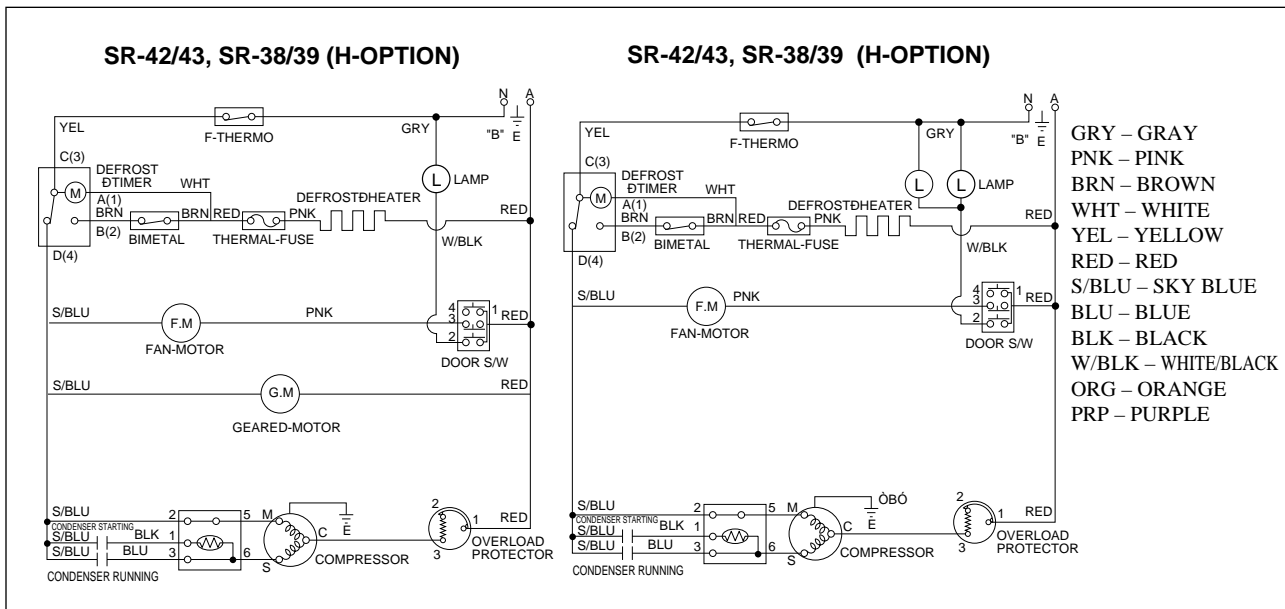

10. Troubleshooting method

10-1 The refrigerator does not operate

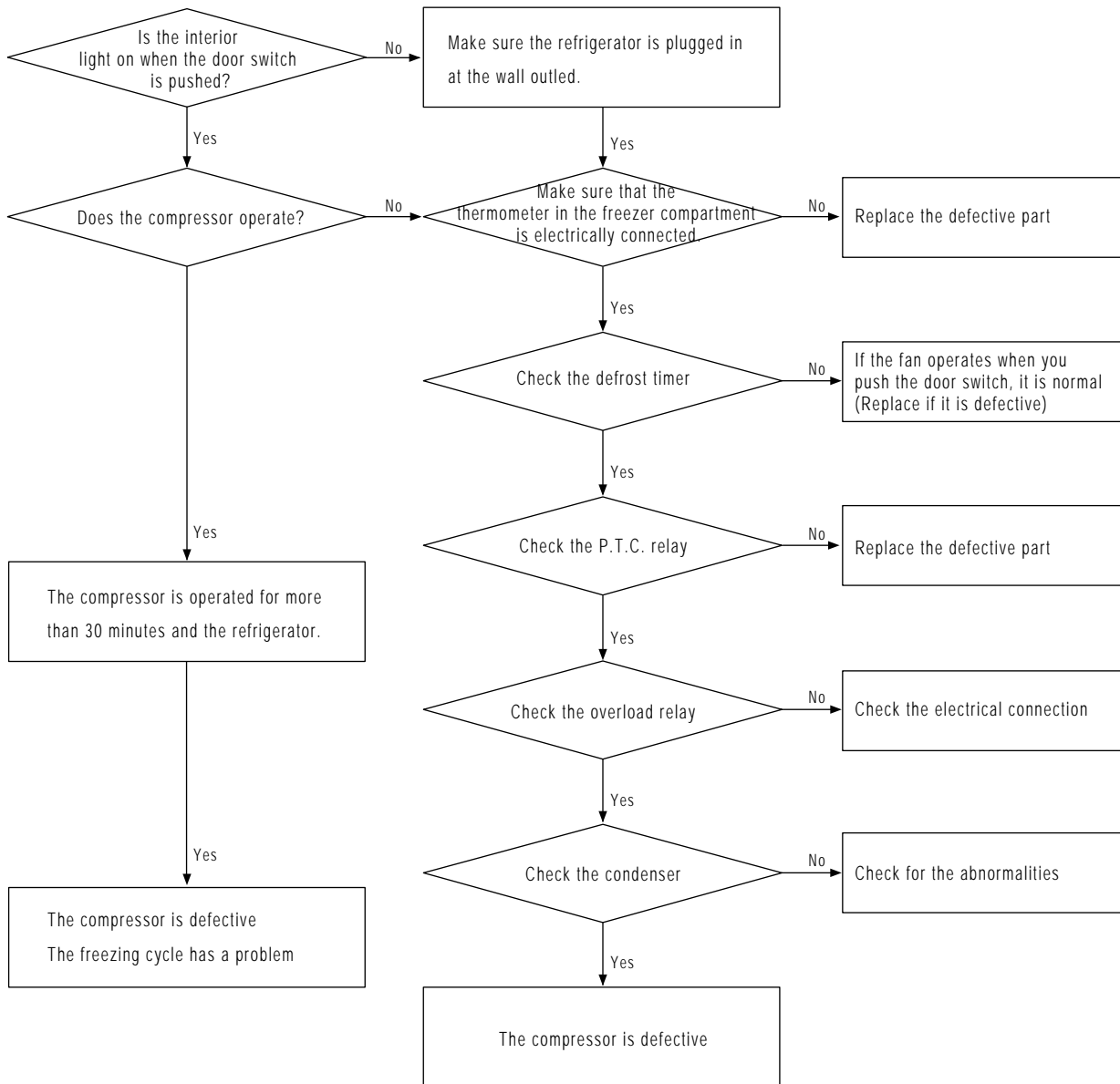

10-2 Defrosting mechanism does not work

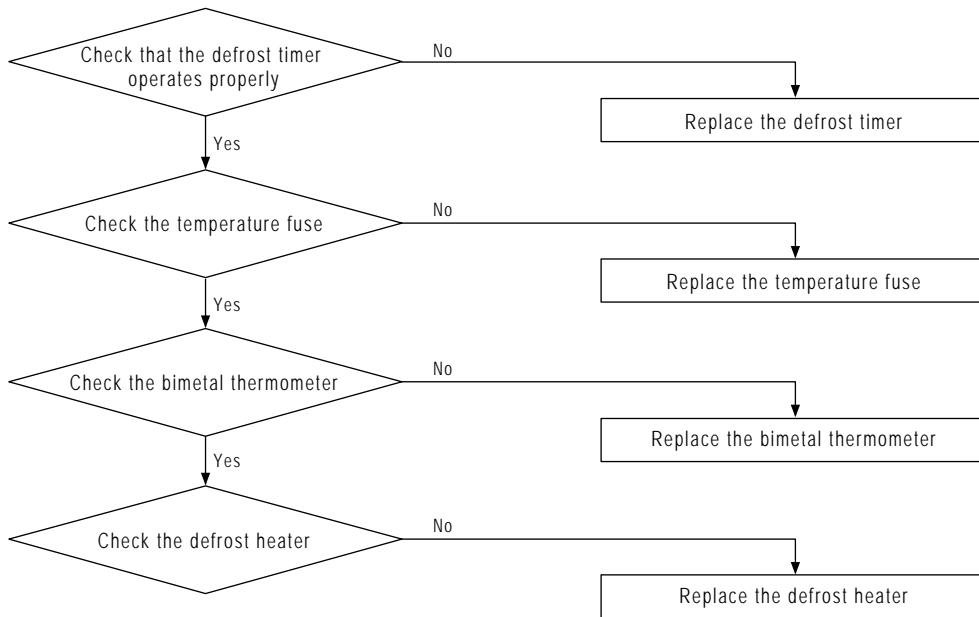

10-3 Defrosting mechanism does not work

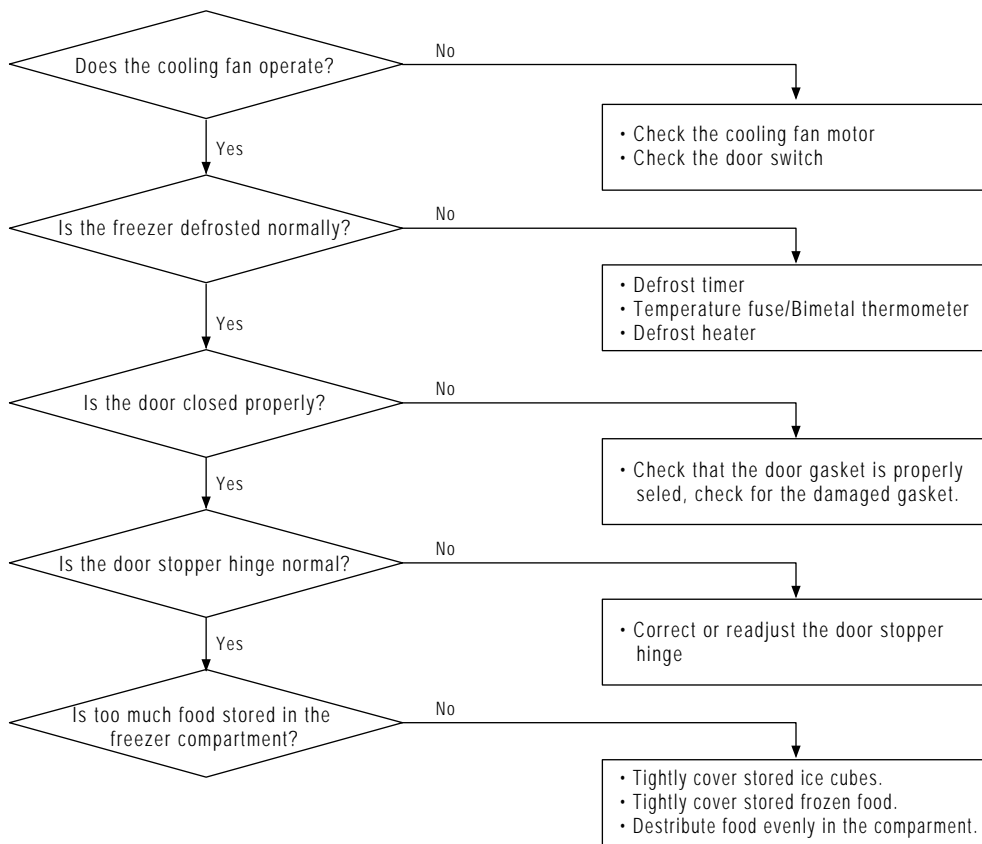

10-4 Trouble check for the cooling cycle

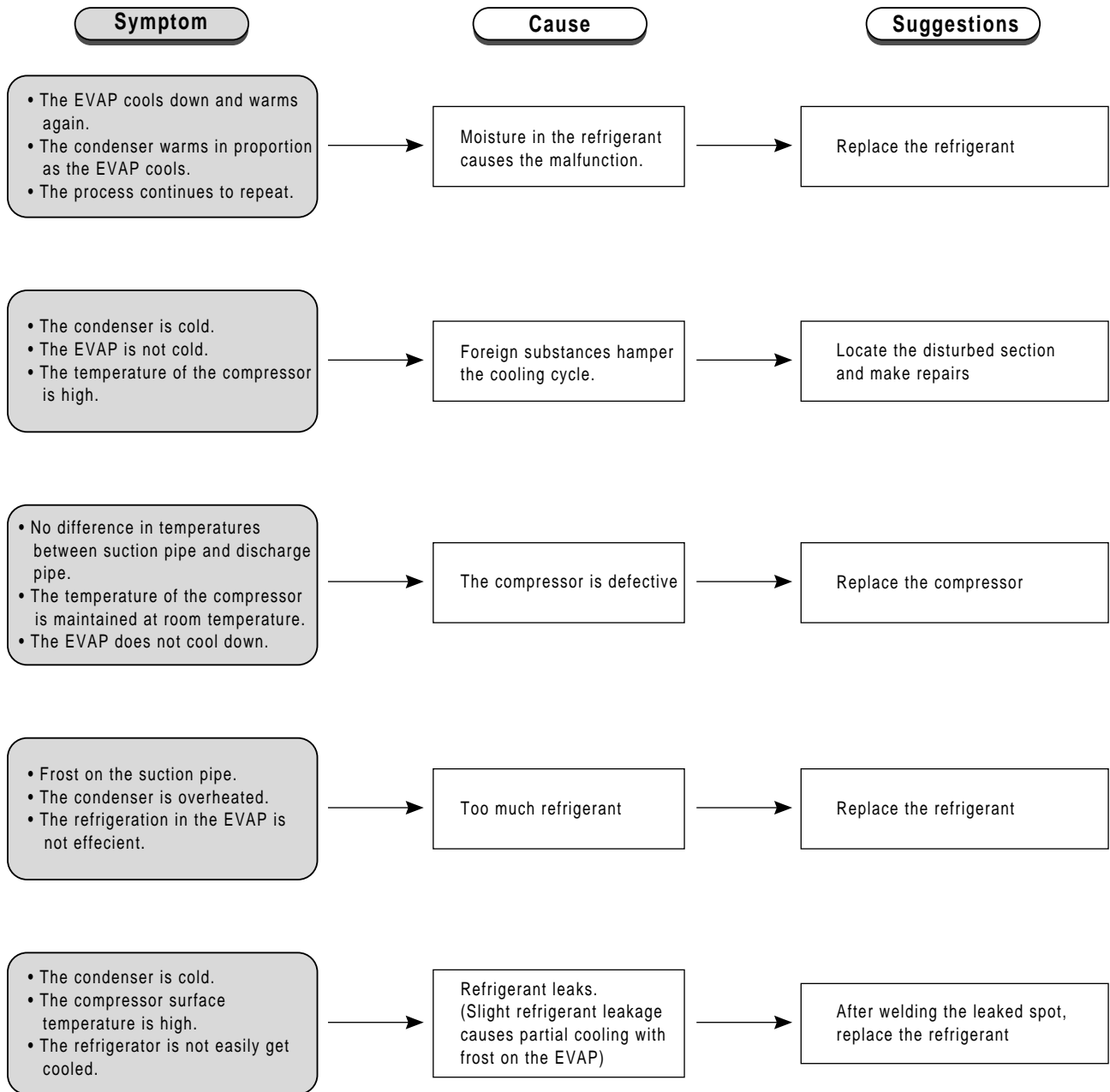

10-5 Diagnosing the main components

Components	Diagnosing methods and criteria	Location								
Compressor	<ul style="list-style-type: none"> Use the tester to measure the resistance. <ul style="list-style-type: none"> Bring the component to cool down completely before measuring. <table border="1"> <thead> <tr> <th>Measuring point</th> <th>Normal</th> <th>Abnormal</th> </tr> </thead> <tbody> <tr> <td>Primary wire</td> <td>Approx 10 ~ 500k</td> <td rowspan="2">0 and</td> </tr> <tr> <td>Secondary wire</td> <td>3 ~ 20</td> </tr> </tbody> </table>	Measuring point	Normal	Abnormal	Primary wire	Approx 10 ~ 500k	0 and	Secondary wire	3 ~ 20	Mechanical compartment
Measuring point	Normal	Abnormal								
Primary wire	Approx 10 ~ 500k	0 and								
Secondary wire	3 ~ 20									
P.T.C Relay	<ul style="list-style-type: none"> Use the tester to measure the resistance. <ul style="list-style-type: none"> Bring the component to cool down completely before measuring. <table border="1"> <thead> <tr> <th>Normal</th> <th>Abnormal</th> </tr> </thead> <tbody> <tr> <td>Approx ~ k</td> <td>0 and</td> </tr> </tbody> </table>	Normal	Abnormal	Approx ~ k	0 and	Mechanical compartment				
Normal	Abnormal									
Approx ~ k	0 and									
Condenser	<ul style="list-style-type: none"> Use the tester to measure the resistance. <ul style="list-style-type: none"> Bring the component to cool down completely before measuring. <table border="1"> <thead> <tr> <th>Normal</th> <th>Abnormal</th> </tr> </thead> <tbody> <tr> <td>Approx 10 ~ 80k</td> <td>0 and</td> </tr> </tbody> </table>	Normal	Abnormal	Approx 10 ~ 80k	0 and	Electrical equipment box				
Normal	Abnormal									
Approx 10 ~ 80k	0 and									
Overload relay	<ul style="list-style-type: none"> Use the tester to measure the resistance. <table border="1"> <thead> <tr> <th>Normal</th> <th>Abnormal</th> </tr> </thead> <tbody> <tr> <td>Approx 200k</td> <td>0 and</td> </tr> </tbody> </table>	Normal	Abnormal	Approx 200k	0 and	Mechanical compartment				
Normal	Abnormal									
Approx 200k	0 and									
Circuit-motor & Fan-motor	<ul style="list-style-type: none"> Use the tester to measure the resistance. <ul style="list-style-type: none"> Bring the component to cool down completely before measuring. <table border="1"> <thead> <tr> <th>Normal</th> <th>Abnormal</th> </tr> </thead> <tbody> <tr> <td>Approx 100 ~ 20k</td> <td>0 and</td> </tr> </tbody> </table>	Normal	Abnormal	Approx 100 ~ 20k	0 and	Mechanical compartment Freezing compartment				
Normal	Abnormal									
Approx 100 ~ 20k	0 and									
Rotating blade geared-motor	<ul style="list-style-type: none"> Use the tester to measure the resistance. <ul style="list-style-type: none"> Bring the component to cool down completely before measuring. <table border="1"> <thead> <tr> <th>Normal</th> <th>Abnormal</th> </tr> </thead> <tbody> <tr> <td>Approx 10 ~ 20k</td> <td>0 and</td> </tr> </tbody> </table>	Normal	Abnormal	Approx 10 ~ 20k	0 and	Refrigerating compartment				
Normal	Abnormal									
Approx 10 ~ 20k	0 and									
Door switch	<ul style="list-style-type: none"> Use the tester to measure the resistance. <table border="1"> <thead> <tr> <th>Measuring point</th> <th>Normal</th> <th>Abnormal</th> </tr> </thead> <tbody> <tr> <td>A B contact point</td> <td rowspan="2">Approx 200M</td> <td rowspan="2">M and</td> </tr> <tr> <td>When the switch is on by the contact</td> </tr> </tbody> </table>	Measuring point	Normal	Abnormal	A B contact point	Approx 200M	M and	When the switch is on by the contact	Between the upper and the lower doors	
Measuring point	Normal	Abnormal								
A B contact point	Approx 200M	M and								
When the switch is on by the contact										
Defrost timer	<ul style="list-style-type: none"> Use the tester to measure the resistance. <table border="1"> <thead> <tr> <th>Measuring point</th> <th>Normal</th> <th>Abnormal</th> </tr> </thead> <tbody> <tr> <td>Between terminals</td> <td>Approx 200K</td> <td rowspan="2">0 and</td> </tr> <tr> <td>Temperature fuse terminal</td> <td>Approx 10 ~300K</td> </tr> </tbody> </table>	Measuring point	Normal	Abnormal	Between terminals	Approx 200K	0 and	Temperature fuse terminal	Approx 10 ~300K	Electrical equipment box
Measuring point	Normal	Abnormal								
Between terminals	Approx 200K	0 and								
Temperature fuse terminal	Approx 10 ~300K									
Defrost heater	<ul style="list-style-type: none"> Use the tester to measure the resistance. <ul style="list-style-type: none"> Bring the component to cool down completely before measuring. <table border="1"> <thead> <tr> <th>Normal</th> <th>Abnormal</th> </tr> </thead> <tbody> <tr> <td>Approx 3K ~ 6K</td> <td>M ~</td> </tr> </tbody> </table>	Normal	Abnormal	Approx 3K ~ 6K	M ~	Lower EVAP				
Normal	Abnormal									
Approx 3K ~ 6K	M ~									
Bimetal Temperature fuse	<ul style="list-style-type: none"> Use the tester to measure the resistance. <table border="1"> <thead> <tr> <th>Measuring point</th> <th>Normal</th> <th>Abnormal</th> </tr> </thead> <tbody> <tr> <td>Bimetal terminal</td> <td rowspan="2">Approx 200M</td> <td rowspan="2">~</td> </tr> <tr> <td>Temperature fuse terminal</td> </tr> </tbody> </table>	Measuring point	Normal	Abnormal	Bimetal terminal	Approx 200M	~	Temperature fuse terminal	EVAP	
Measuring point	Normal	Abnormal								
Bimetal terminal	Approx 200M	~								
Temperature fuse terminal										

11. Exploded View & Parts List

11-1 Freezing compartment

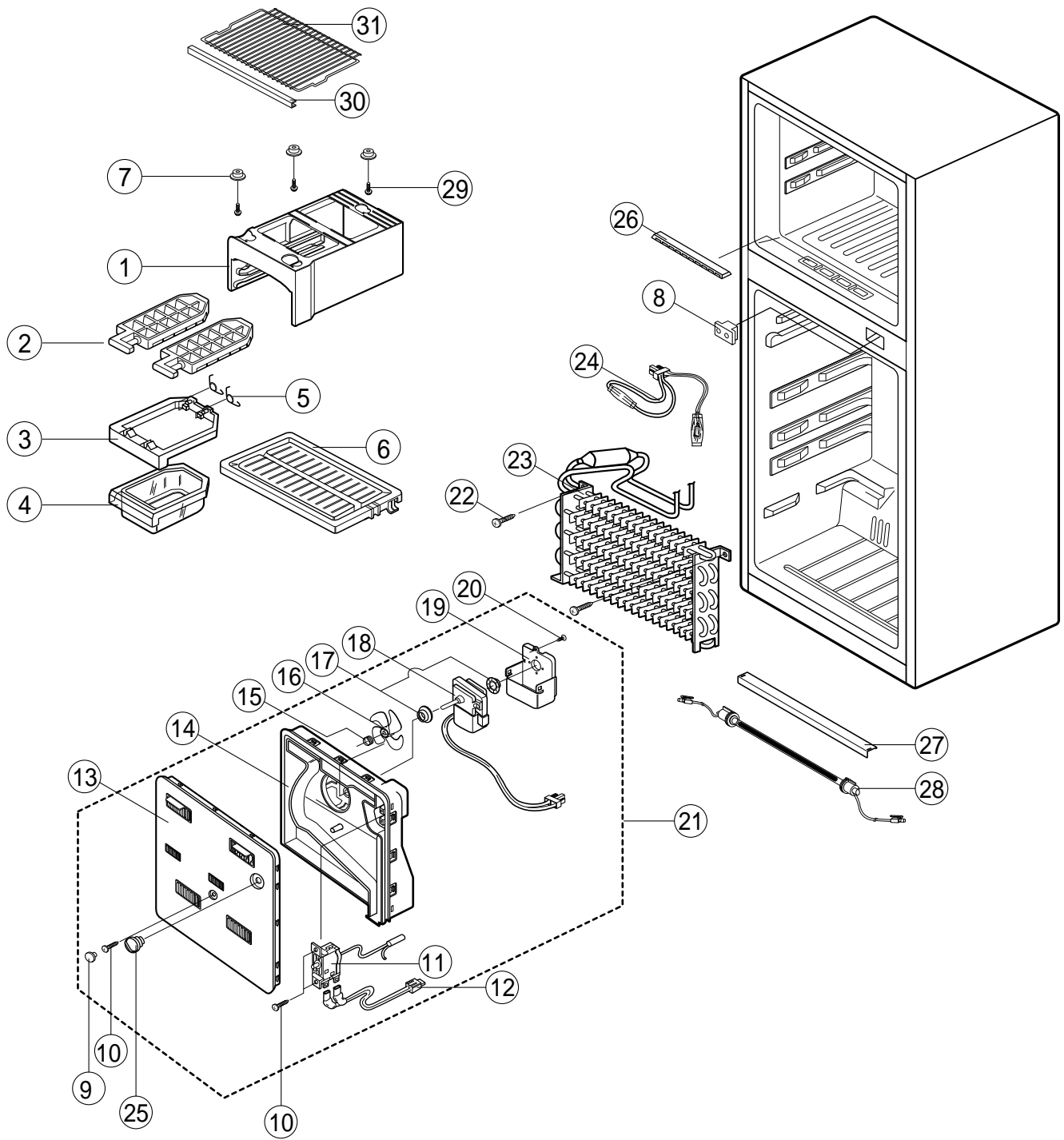

NO	CODE-NO	DESCRIPTION	SPECIFICATION	SR-42/43					SR-38/39					
				H	M	L	N	G	H	M	L	N	G	
1	DA61-70002A	BASE-TRAY, ICE	HIPS	1	1	1	1	1	1	1	1	1	1	1
2	DA67-40180A	TRAY-ICE(A)	P.P	2	2	2	2	2	2	2	2	2	2	2
3	DA67-10126A	CASE-TRAY, ICE	HIPS	1	1	1	1	1	1	1	1	1	1	1
4	DA67-10210C	TRAY-ICE, CUBE(A)	GPPS	1	1	1	1	1	1	1	1	1	1	1
5	DA61-20119A	SPRING-ICE	PII.0 L162.6	2	2	2	2	2	2	2	2	2	2	2
6	DA67-20137A	SHELF-FRE	GPPS	1	1	1	0	0	1	1	0	0	0	0
7	DA71-20252A	FIXER-GROMMET D/FRE	ABS	3	3	3	3	3	3	3	3	3	3	3
8	3523-202-340	SWITCH-DOOR	NY 694 VO	1	1	1	1	1	1	1	1	1	1	1
9	DA67-30266D	CAP-SCREW	P,P	1	1	1	1	1	1	1	1	1	1	1
10	6002-000454	SCREW-TAP, TH	2-4 x 12 STS304	2	2	2	2	2	2	2	2	2	2	2
11	DA47-10107H	THERMOSTAT	PCC PFN174S	1	1	1	1	1	1	1	1	1	1	1
12	DA39-20124B	WIRE-LEAD, THERMO	-	1	1	1	1	1	1	1	1	1	1	1
13	DA63-10253L	COVER-EVAP, FR	P.P	1	1	1	1	1	1	1	1	1	1	1
14	DA63-10254A	COVER-EVAP, RE	ABS SCRAP	1	1	1	1	1	1	1	1	1	1	1
15	DA61-20128B	SPRING-FAN	STS 27	1	1	1	1	1	1	1	1	1	1	1
16	DA31-20002A	FAN	ABS	1	1	1	1	1	1	1	1	1	1	1
17	DA63-40119A	GROMMET-FAN, MOTOR	SILICON	2	2	2	2	2	2	2	2	2	2	2
18	DA31-10109S	MOTOR (220~240V)	AMRHB-010WTEB	1	1	1	1	1	1	1	1	1	1	1
	DA31-10109V	“(110V~127V)	AMRHB-010ZQRB	1	1	1	1	1	1	1	1	1	1	1
19	DA63-10459A	COVER-FAN, MOTOR	P.P	1	1	1	1	1	1	1	1	1	1	1
20	6002-000454	SCREW-TAP, TH	1-4 x 12 FE, FZY	1	1	1	1	1	1	1	1	1	1	1
21	DA63-10998R	COVER-EVAP,ASSY(110V~127V)		1	1	1	1	1	1	1	1	1	1	1
	DA63-10998Q	COVER-EVAP,ASSY(220V~240V)												
22	6002-000213	SCREW-TAP,TH	2-4 x 12 STS304	2	2	2	2	2	2	2	2	2	2	2
23	DA59-40129A	EVAPORATOR	-	1	1	1	1	1	1	1	1	1	1	1
24	DA47-10103J	BIMETAL-THERMO	125, 250/50, 60-5/12	1	1	1	1	1	1	1	1	1	1	1
25	DA64-40126C	KNOB-F, THERMO	ABS	1	1	1	1	1	1	1	1	1	1	1
26	DA63-10886A	COVER-AIR	P.P	1	1	1	1	1	1	1	1	1	1	1
27	DA63-10488B	COVER-HEATER	A1050	1	1	1	1	1	1	1	1	1	1	1
28	DA47-20195F	HEATER-DEFROST	220V/130W	1	1	1	1	1	1	1	1	1	1	1
	DA47-20195H	“	240V/130W	1	1	1	1	1	1	1	1	1	1	1
	DA47-20195G	“	110V/130W	1	1	1	1	1	1	1	1	1	1	1
	DA47-20195J	“	127V/130W	1	1	1	1	1	1	1	1	1	1	1
29	6002-000454	SCREW-TAP,TH	2-4 x 12 STS304	3	3	3	3	3	3	3	3	3	3	3
30	DA64-20150M	TRIM-SHELF	RD-PVC	0	0	0	1	1	0	0	1	1	1	1
31	DA67-20168B	SHELF-FRE(WIRE)	MSWR10	0	0	0	1	1	0	0	1	1	1	1

Indicated part is for electrical safety components

11-2 Refrigerating compartment

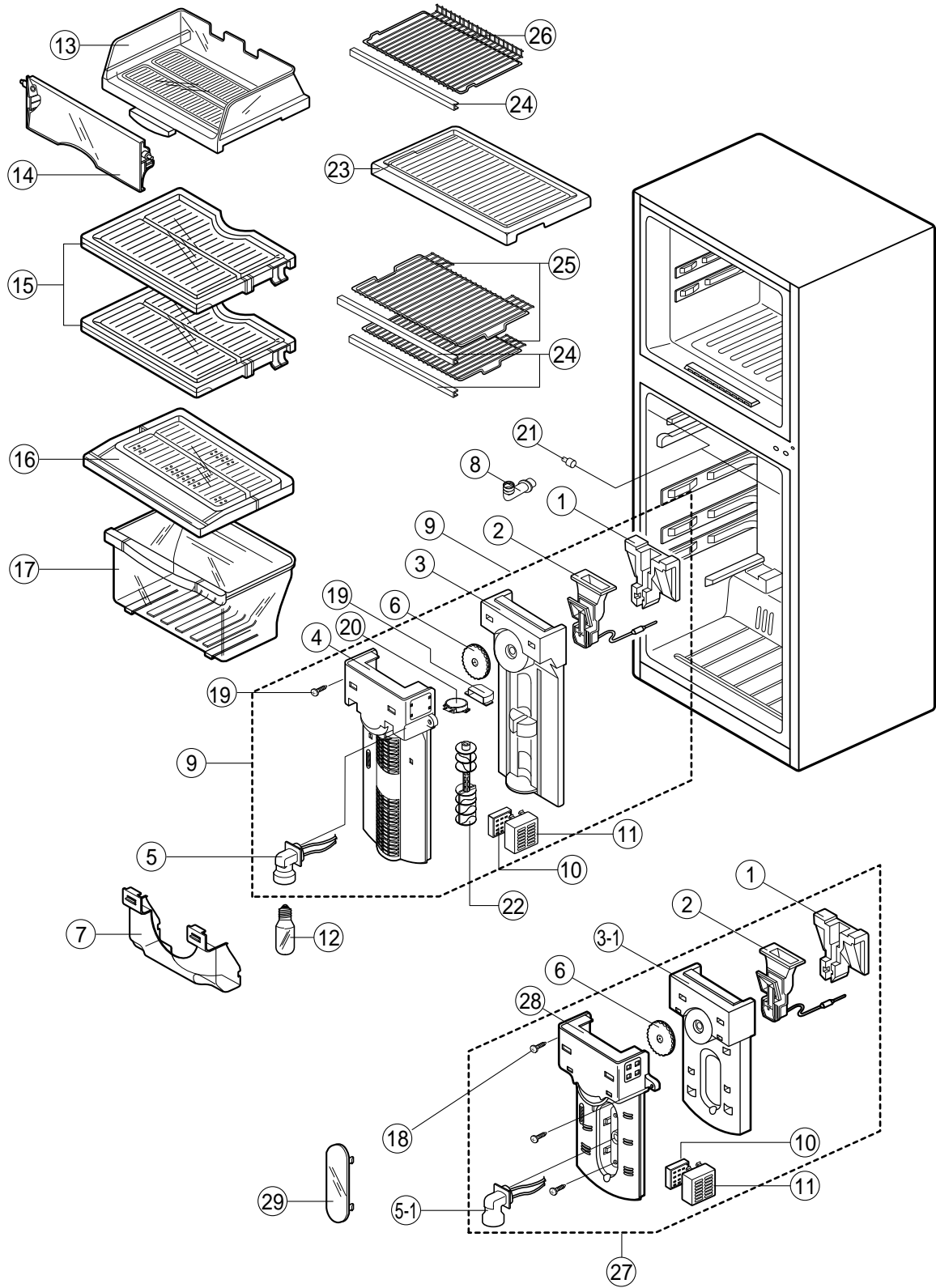

NO	CODE-NO	DESCRIPTION	SPECIFICATION	SR-42/43					SR-38/39				
				H	M	L	N	G	H	M	L	N	G
1	DA72-40193B	SPACER-DAMPER, B	FOAM-PS	1	1	1	1	1	1	1	1	1	1
2	DA67-10246B	ASSY-THERMO, DAMPER	705-E9C	1	1	1	1	1	1	1	1	1	1
3	DA72-40235A	SPACER-DAMPER, A	FOAM-PS	1	0	0	0	0	1	0	0	0	0
3-1	DA72-40194B	SPACER-DAPMER, A	FOAM-PS	0	1	1	1	1	0	1	1	1	1
4	DA63-30142A	COVER-MULTI, REF(X)	P.P	1	0	0	0	0	1	0	0	0	0
5	DA47-40112L	SOCKET-LAMP	250V 1A	1	0	0	0	0	1	0	0	0	0
5-1	DA47-40114D	SOCKET-LAMP(B)	250V 1A	0	1	1	1	1	0	1	1	1	1
6	DA64-10147	KNOB-DAMPER, THERMO.	ABS	1	1	1	1	1	1	1	1	1	1
7	DA63-10395B	COVER-LAMP, REF	MIPS	1	0	0	0	0	1	0	0	0	0
8	DA74-30135A	HOSE-DRAIN, CONNECT	SILICON	1	1	1	1	1	1	1	1	1	1
9	DA47-30153B	ASSY-DAMPER	SR-38/39(110~127V)	1	0	0	0	0	0	0	0	0	0
	DA47-30153C	ASSY-DAMPER	SR-38/39(220~240V)	1	0	0	0	0	0	0	0	0	0
	DA4730153D	ASSY-DAMPER	SR42/43(110~127V)	0	0	0	0	0	1	0	0	0	0
	DA47-30153E	ASSY-DAMPER	SR-42/43(220~240V)	0	0	0	0	0	1	0	0	0	0
10	DA02-90108A	CATALYST-LTC	T5 W42 L42	1	1	0	0	0	0	0	0	0	0
11	DA63-10487A	CAP-PURIFIER	P.P	1	1	0	0	0	0	0	0	0	0
12	4713-001035	LAMP	110V/127W	2	1	1	1	1	2	1	1	1	1
	4713-000213	“	220V~240V	2	1	1	1	1	2	1	1	1	1
13	DA64-40140A	TRAY-CHILLED, ROOM	GPSS	1	1	0	0	1	1	1	0	0	1
14	DA63-10982C	COVER-CHILLED, ROOM	“	1	1	0	0	1	1	1	0	0	1
15	DA67-20138A	SHELF-REF	“	2	2	2	0	0	2	2	2	0	0
16	DA63-10255A	COVER-VEGETABLE	“	1	1	1	1	1	1	1	1	1	1
17	DA67-10197A	TRAY-VEGETABLE	“	1	1	1	1	1	1	1	1	1	1
18	6002-000471	SCREW-TAP, TH	1-4 x 12 STS304	2	2	2	2	2	2	2	2	2	2
19	DA63-40134A	GROMMET-MOTOR	NBR	1	0	0	0	0	1	0	0	0	0
20	DA31-10107D	GEARED-MOTOR	M2LC18AR01(220~240V)	1	0	0	0	0	1	0	0	0	0
	DA31-10107E	“	M2BC18AR01(110~127V)	1	0	0	0	0	1	0	0	0	0
21	DA63-40131A	FIXER-CHILLED, ROOM	ABS	2	2	0	0	2	2	2	0	0	2
22	DA31-20108A	BLADE-DAMPER	ABS	1	0	0	0	0	1	0	0	0	0
23	DA67-20139A	SHELF-CHILLED	GPSS	0	0	1	0	0	0	0	1	0	0
24	DA64-20150P	TRIM-SHELF	RD-PVC	0	0	0	3	2	0	0	0	3	2
25	DA67-20022A	SHELF-REF(WIRE)	MSWR10	0	0	0	2	2	0	0	0	2	2
26	DA67-20024B	SHELF-CHILLED(WIRE)	“	0	0	0	1	0	0	0	0	1	0
27	DA47-30152D	ASSY-DAMPER (MULTI)	SR-38/39,DEODO.(C)	0	1	1	0	0	0	0	0	0	0
			SR-42/43,DEODO.	0	0	0	1	1	0	0	0	0	0
	DA47-30152E	ASSY-DAMPER (MULTI)	SR-38/39, NO. DEODO.	0	0	0	0	0	0	1	1	0	0
			SR-42/43, NO.DEODO.	0	0	0	0	0	0	0	0	1	1
28	DA47-30102	COVER-MULTI, REF(M)	P.P	0	1	1	1	1	0	1	1	1	1
29	DA63-10388A	COVER-LAMP, REF	MIPS	0	1	1	1	1	0	1	1	1	1

Indicated part is for electrical safety components

11-3 Door parts

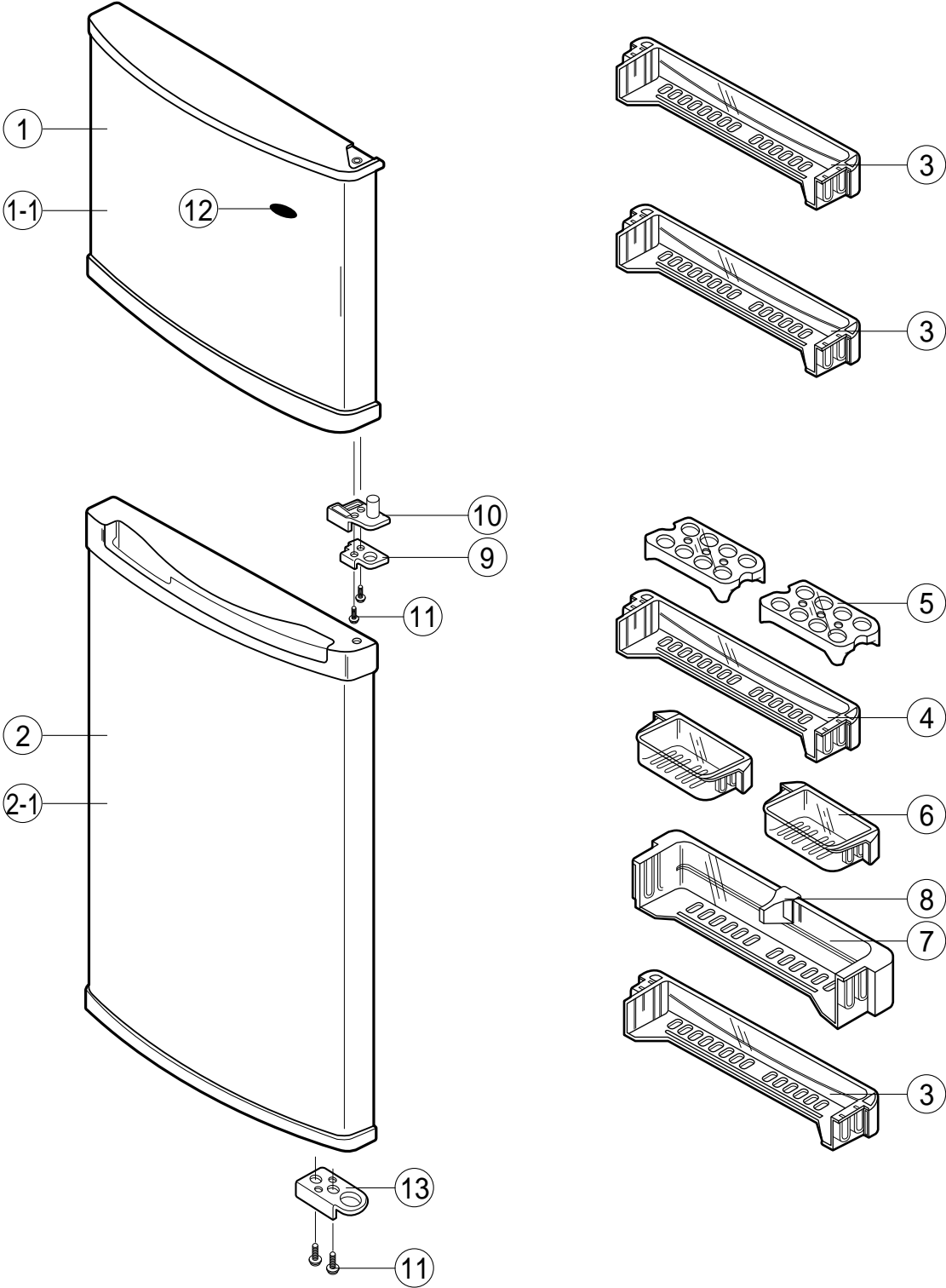

NO	CODE-NO	DESCRIPTION	SPECIFICATION	SR-42/43					SR-38/39				
				H	M	L	N	G	H	M	L	N	G
1	DA91-40193B	ASSY-FOAM DOOR, FRE	SR-42/43 OPTION	1	1	1	1	1	0	0	0	0	0
1-1	DA91-10246B	"	SR-38/39 OPTION	0	0	0	0	0	1	1	1	1	1
2	DA91-40235A	ASSY-FOAM DOOR, REF	SR-42/43 OPTION	1	1	1	1	1	0	0	0	0	0
2-1	DA91-40194B	"	SR-38/39 OPTION	0	0	0	0	0	1	1	1	1	1
3	DA63-30142A	GUARD-FRE(REF)	GPPS	3	3	3	3	3	3	3	3	3	3
4	DA63-40112L	GUARD-EGG	"	1	1	1	1	1	1	1	1	1	1
5	DA67-40114D	TRAY-EGG	"	2	2	2	2	2	2	2	2	2	2
6	DA63-10147	GUARD-VARIETY	"	2	2	2	2	2	2	2	2	2	2
7	DA63-10395B	GUARD-JUMBO	"	1	1	1	1	1	1	1	1	1	1
8	DA71-30135A	GUIDE-BOTTLE, JUMBO	P.P	1	1	1	1	1	1	1	1	1	1
9	DA71-30142	STOPPER-DOOR(C)	SCP1 T2.0 ZPC3	1	1	1	1	1	1	1	1	1	1
10	DA71-90108A	STOPPER-DOOR(A)	POM	1	1	1	1	1	1	1	1	1	1
11	6001-10487A	SCREW-MACHINE	TH M4X12 STS304	4	4	4	4	4	4	4	4	4	4
12		INLAY-MASCOT	PET	1	1	1	1	1	1	1	1	1	1
13	DA71-000213	STOPPER-DOOR(B)	SCP1 T2.5 ZPC	1	1	1	1	1	1	1	1	1	1

Indicated part is for electrical safety components

11-4 Cabinet Parts & Unit

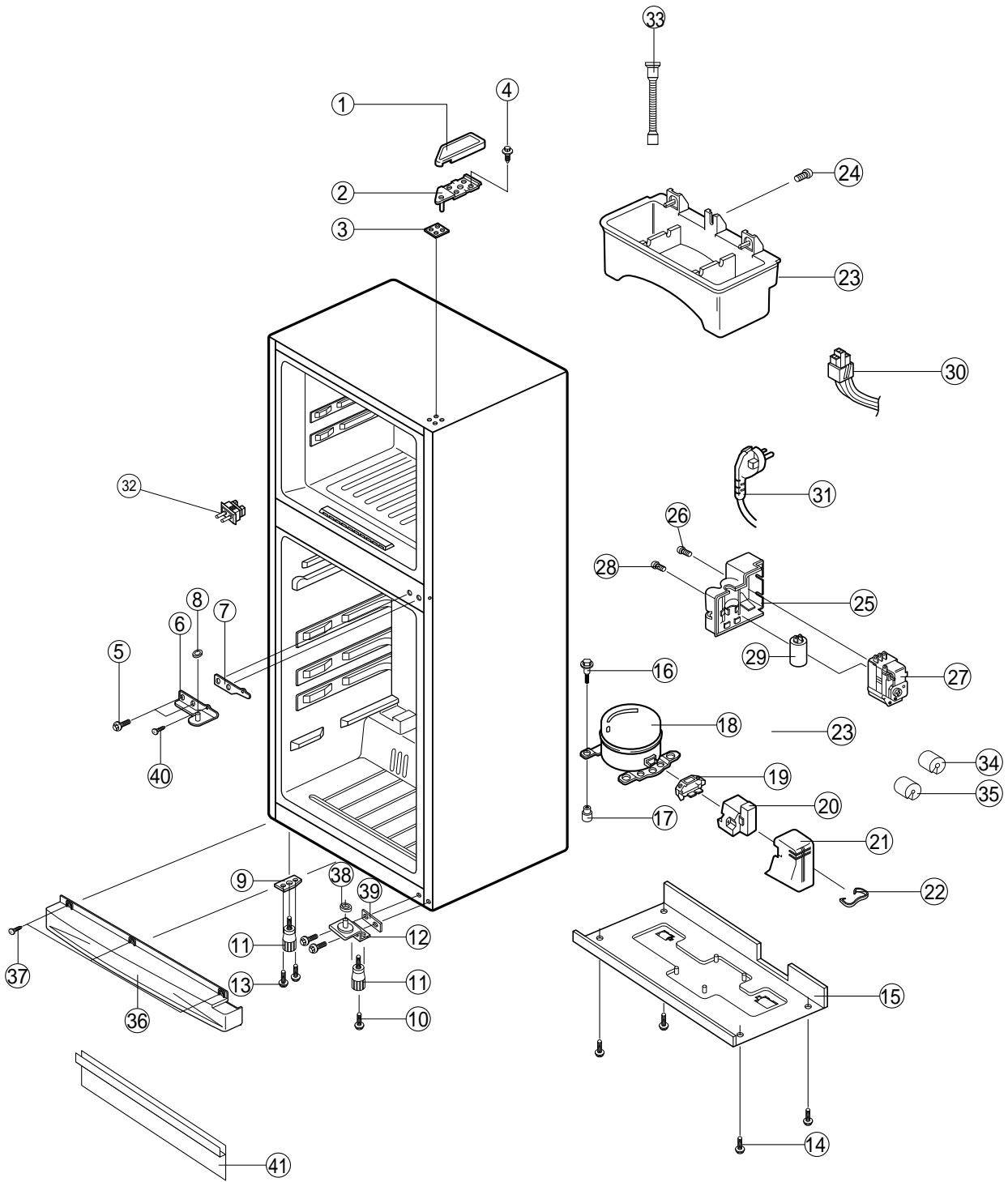

NO	CODE-NO	DESCRIPTION	SPECIFICATION	SR-42/43					SR-38/39					
				H	M	L	N	G	H	M	L	N	G	
1	DA63-10969A	COVER-HINGE, UP	PP	1	1	1	1	1	1	1	1	1	1	1
2	DA61-10213A	HINGE, UP	SCP1 T2.5 ZPC3	1	1	1	1	1	1	1	1	1	1	1
3	DA63-50145A	SHIM-HINGE, UP	RD-PVC	1	1	1	1	1	1	1	1	1	1	1
4	DA60-10124A	SCREW-TAP, TITE	ZPC2-Y M6X16	4	4	4	4	4	4	4	4	4	4	4
5	DA61-10213C	SCREW-TAP, TITE	ZPC2-W M6X24	2	2	2	2	2	2	2	2	2	2	2
6	DA61-10214A	HINGE-MID	SCP1 T4 ZPC2	1	1	1	1	1	1	1	1	1	1	1
7	DA63-50159A	SHIM-HINGE, MID	RD-PVC T1.0	1	1	1	1	1	1	1	1	1	1	1
8	DA60-40102A	WASHER	ID8.50D16T1 NY-66	1	1	1	1	1	1	1	1	1	1	1
9	DA61-70256A	SUPT-FOOT	SHP1 T4.5 ZPC3	2	2	2	2	2	2	2	2	2	2	2
10	DA60-10124A	SCREW-TAP, TITE	ZPC2-Y M6X16	3	3	3	3	3	3	3	3	3	3	3
11	DA61-30105A	FOOT-FRONT	PP	2	2	2	2	2	2	2	2	2	2	2
12	DA61-10150A	HINGE-LOW	SHP1 T4.5 ZPC3	1	1	1	1	1	1	1	1	1	1	1
13	6001-000034	SCREW-TH	STS M4X15	4	4	4	4	4	4	4	4	4	4	4
14	DA60-10124A	SCREW-TAP, TITE	ZPC2-Y M6X16	4	4	4	4	4	4	4	4	4	4	4
15	DA71-60196B	BASE-COMP, ASSY	SBHG1 T1.2	1	1	1	1	1	1	1	1	1	1	1
16	DA65-20101A	CLAMP-COMP	SK5	4	4	4	4	4	4	4	4	4	4	4
17	DA63-40004A	GROMMET-COMP	NBR	4	4	4	4	4	4	4	4	4	4	4
18	SD162H-L1U2	COMPRESSOR	220V/50Hz,60Hz	1	1	1	1	1	1	1	1	1	1	1
	SD162Q-L1U2	COMPRESSOR	230V~240V/50Hz	1	1	1	1	1	1	1	1	1	1	1
	SD162C-L1W2	COMPRESSOR	100~115V/60Hz	1	1	1	1	1	1	1	1	1	1	1
	SD162P-L1W2	COMPRESSOR	127V/60Hz	1	1	1	1	1	1	1	1	1	1	1
19	DA34-10003R	O/L-PROTECTOR (115/60)	4TM427PHBYY-53	1	1	1	1	1	1	1	1	1	1	1
	DA34-10003U	O/L-PROTECTOR (127/60)	4TM317RHYY-53	1	1	1	1	1	1	1	1	1	1	1
	DA34-10003A	O/L-PROTECTOR (220/50)	4TM265RHYY-53	1	1	1	1	1	1	1	1	1	1	1
	DA34-10003X	O/L-PROTECTOR (240/50)	4TM222PHBYY-53	1	1	1	1	1	1	1	1	1	1	1
20	DA35-10002C	PTC-RELAY	912X32E100MQ16APE3	1	1	1	1	1	1	1	1	1	1	1
	DA35-10002D	PTC-RELAY	912X35E330MT20APE2	1	1	1	1	1	1	1	1	1	1	1
21	DA63-10722A	COVER-RELAY	PP	1	1	1	1	1	1	1	1	1	1	1
22	DA65-10002A	CLAMP-RELAY, COVER	SK-5	1	1	1	1	1	1	1	1	1	1	1
23	DA67-40309A	TRAY-DRAIN, WATER	PP	1	1	1	1	1	1	1	1	1	1	1
24	6002-000213	SCREW-TAP, TH	1-4X12 FE, FZY	2	2	2	2	2	2	2	2	2	2	2
25	DA67-10430C	CASE-JUNCTION	PP	1	1	1	1	1	1	1	1	1	1	1
26	6002-000213	SCREW-TAP, TH	1-4X12 FE, FZY	1	1	1	1	1	1	1	1	1	1	1
27	DA45-10003F	TIMER-DEFROST	100V~127V 6H40M	1	1	1	1	1	1	1	1	1	1	1
	DA45-10003E	TIMER-DEFROST	220V~240V 6H40M	1	1	1	1	1	1	1	1	1	1	1

Indicated part is for electrical safety components

NO	CODE-NO	DESCRIPTION	SPECIFICATION	SR-42/43					SR-38/39				
				H	M	L	N	G	H	M	L	N	G
28	6002-000213	SCREW-TAP, TH	1-4X12 FE, FZY	2	2	2	2	2	2	2	2	2	2
29	2501-000413	C-OIL (RUN)	8μF/250VAC	1	1	1	1	1	1	1	1	1	1
	2501-000427	C-OIL (RUN)	3.5μF/350VAC	1	1	1	1	1	1	1	1	1	1
	2501-000422	C-OIL (START)	100μF/125VAC	1	1	1	1	1	1	1	1	1	1
30	DA39-20386C	WIRE-HARNESS RELAY	220V~240V	1	1	1	1	1	1	1	1	1	1
	DA39-20386D	WIRE-HARNESS RELAY	100V~127V	1	1	1	1	1	1	1	1	1	1
31		CBF	BUYER OPTION	1	1	1	1	1	1	1	1	1	1
32	DA34-10122C	SWITCH-DOORDRAIN-	GRN 2B	1	1	1	1	1	1	1	1	1	1
33	DA74-30131A	HOSE, B	LDPE	1	1	1	1	1	1	1	1	1	1
34	DA63-40237G	GROMMET-DISCHARGE	NBR P16	1	1	1	1	1	1	1	1	1	1
35	DA63-40237H	GROMMET-DISCHARGE	NBR P14	1	1	1	1	1	1	1	1	1	1
36	DA63-10252A	COVER-TRAY WATER	PP	1	1	1	1	1	1	1	1	1	1
37	6002-000213	SCREW-TAP,TH	1-4X12FE, FZY6	3	3	3	3	3	3	3	3	3	3
38	DA60-41120B	WASHER	ID8.5 0D16 T0.5	1	1	1	1	1	1	1	1	1	1
39	DA63-50196A	SHIM-HINGE, LOW	RD-PVC	1	1	1	1	1	1	1	1	1	1
40	6002-000453	SCREW-TAPPING	FH M4X12 STS304	1	1	1	1	1	1	1	1	1	1
41	DA64-20189A	TRIM-PLATE ABSOBER	PVC	1	1	1	1	1	1	1	1	1	1

Indicated part is for electrical safety components

8. Packing dimension

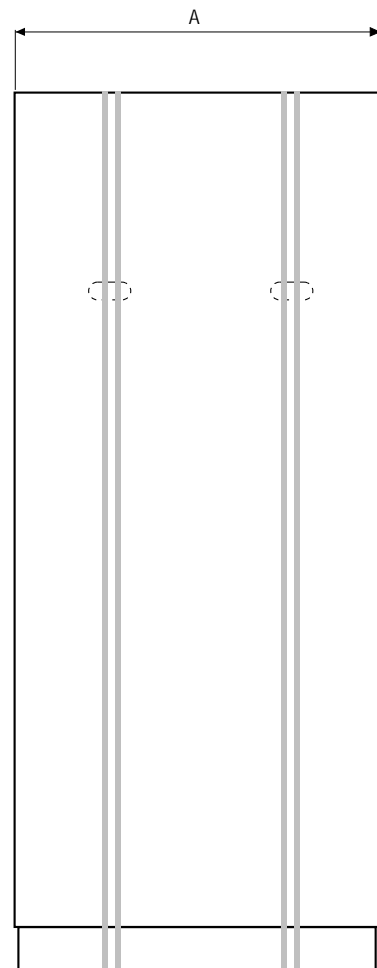
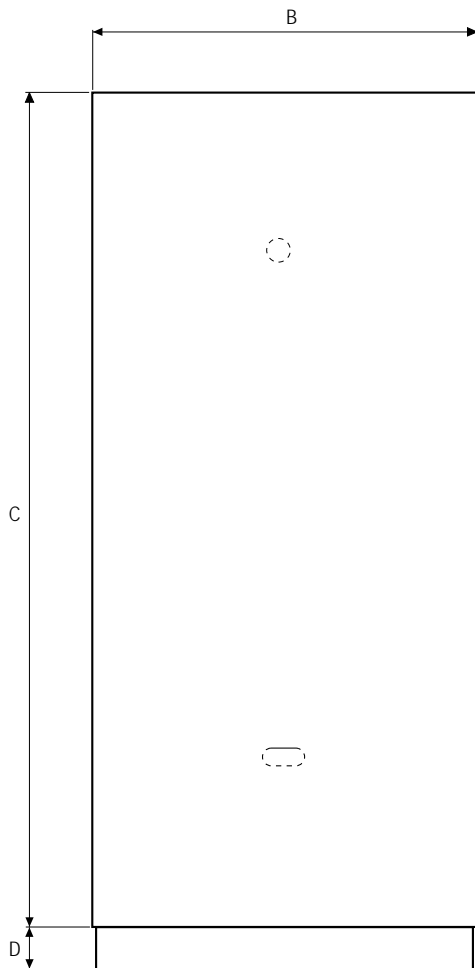
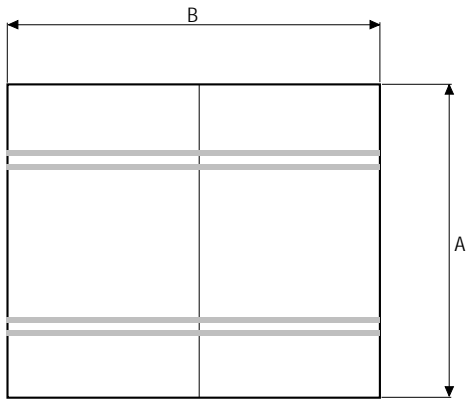

MODEL	A	B	C	D
SR-42/43	695	717	1806	55
SR-38/39	695	717	1729	55

9. Schematic diagram of cold air flow

- Cold air generated from the cooling system is distributed to the freezing compartment and the refrigerating compartment by the air circulation fan.
- In the freezing compartment, cold air is distributed to the shelves from the cold air exhaust port, food is frozen in the freezing compartment by cold air shower. Cold air that comes out of the freezing compartment is absorbed back to the lower part of the cooling system through the suction port on the median divider.
- In the refrigerating compartment, cold air is distributed to the damper cover through the median divider. Cold air supplied to the damper cover passes through the rotating blade and evenly cools the refrigerating compartment. After cooling the refrigerating compartment, cold air is absorbed to the lower part of the cooling system through the suction port on the median divider.

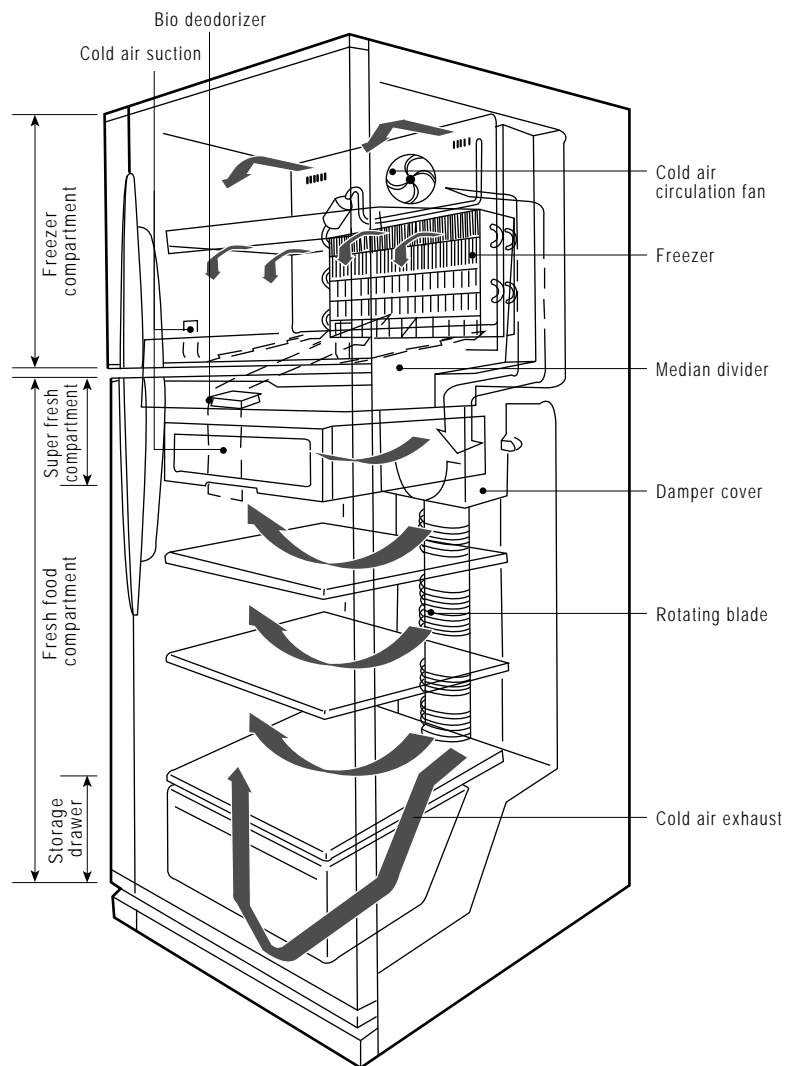

[SR-42/43,SR-38/39]

12. How to disassemble of freezing compartment

12-1 COVER-EVAP.ASSY'Y

1) Take out the items in the freezer

2) Dry off the wetness in the handle.

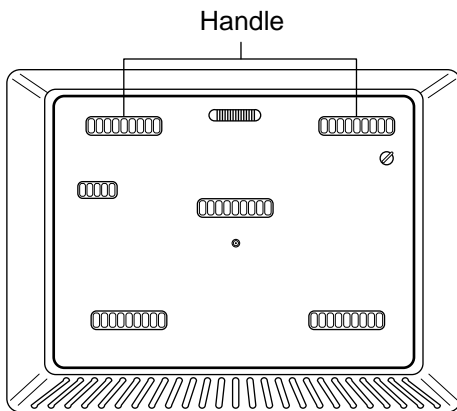

3) Hold the handle with the hand and press the elbow towards the COVER-EVAP, ASSY and press force downwards.

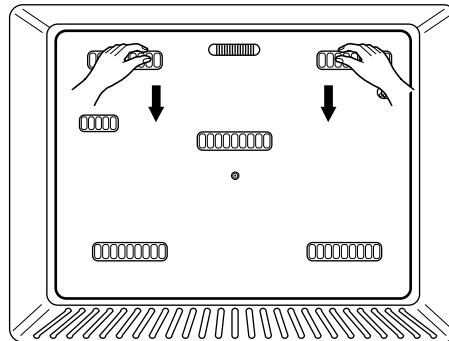

4) While pressing force downwards, pull the handle towards the front at the same time.

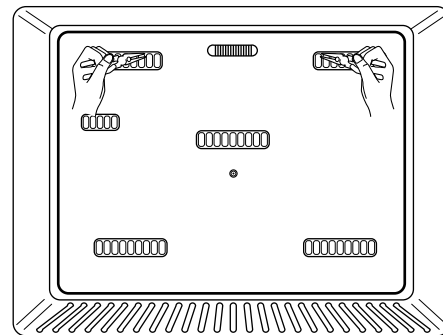
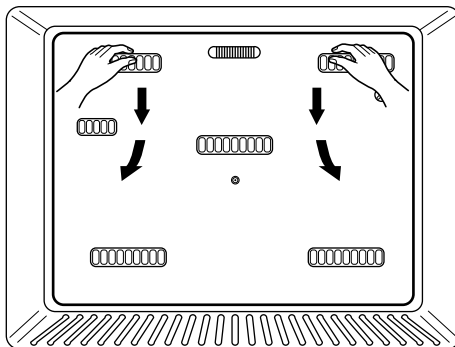

Reference : to improve the friction of the handle, use rubber gloves or pick-up tongs.

5) When the COVER-EVAP, ASSY is taken apart, take the necessary corrective measures and this time put them together.

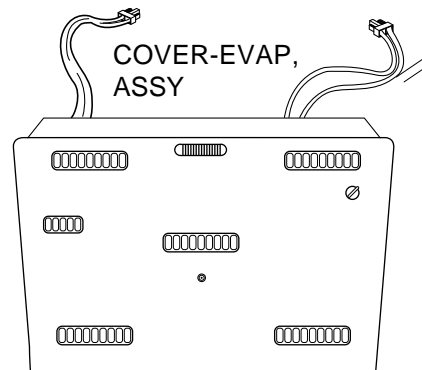
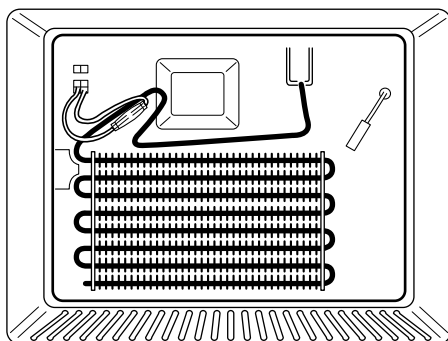

13. How to disassemble of refrigerating compartment

1. Remove the super fresh compartment cover and its shelf.

- Lift up the cover, push the cover (as shown) until the mounting hook (1) disengages, then disengage the other mounting hook (2) and pull out the cover.
- Pull the shelf forward until it stops, then lift it up and pull it out.

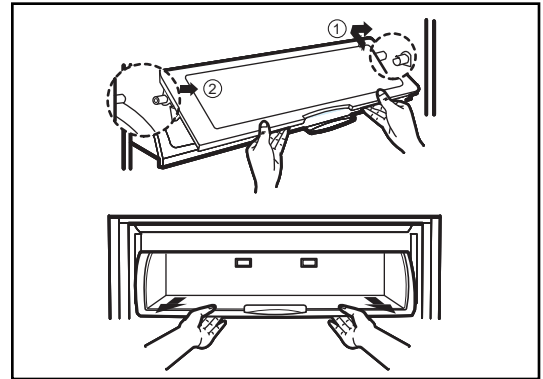

2. Remove the shelves from the fresh food compartment.

- First remove food from the compartment. With shelf front raised slightly, pull it forward to disengage.

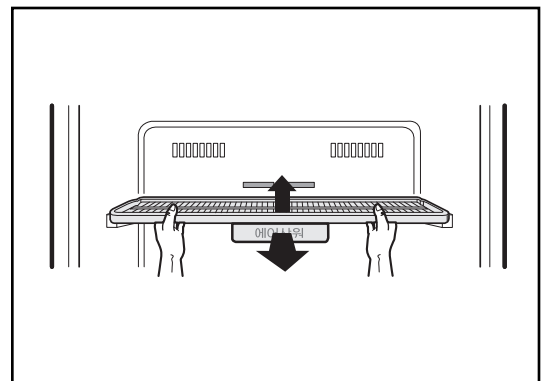

3. Disengage the hooks on the lamp cover of the damper cover.

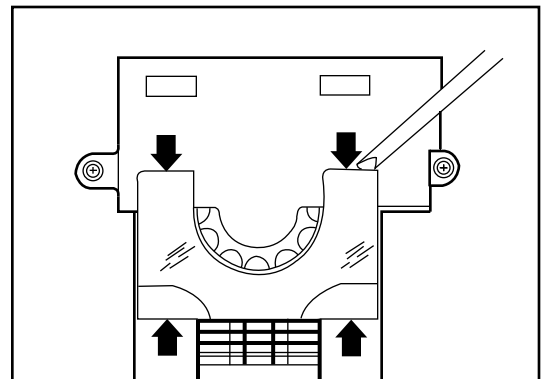

4. Replace the bulb.
(Before replacing, check the voltage and current of the bulb. Use rated bulbs only.)

