

SC18G, 104G8820, Universal, Compressor, R134a, 220-240V 50/60Hz, DANFOSS, SECOP, R134a, HMBP, 1/2 Hp++, displacement 17.70 cc, CSIR, SC18G 104G8820

Category: compressor

written by www.mbsm.pro | 12 December 2021

Compresseur Danfoss SC18G - R134a

Cylindrée = 17.69 CM3

APPLICATIONS = HP; BP; MP

Moteur = CSIR

220-240V 50/60Hz



Design

Displacement	cm ³	17.69
Oil quantity	cm ³	600 (550 on comp. with oil cooler)
Maximum refrigerant charge	g	1300
Free gas vol. in compressor	cm ³	1460
Weight without electrical equipment	kg	13.7

Motor

Motor size	watt	495
LRA (rated after 4 sec. UL984) HST	A	18.6
Cut-in current HST	A	18.6
Resistance, main and start winding (25°C)	Ω	3.7/14.1
Approvals		EN 60335-2-34, CCIB

Dimensions

104G8830 104G8820 104G8822

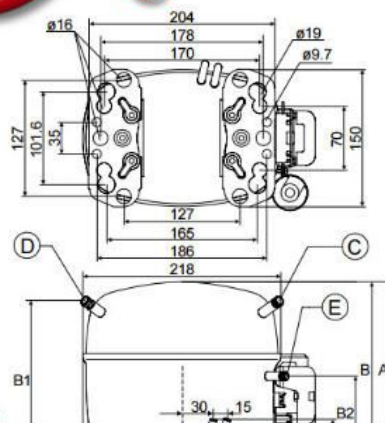

Private Picture Copyright: WWW.MBSM.PRO

Détails du produit

Poids brut 13.8 kg

Poids Net 13.8 kg

Applications

Charge en fluide frigorigène [kg] [Max]

Charge en huile [L]

Code de configuration

Couleur

Courant d'appel HST [A]

Description

Diamètre de raccordement à l'aspiration [mm]

HBP

LBP

MBP

1.3 kg

600 L

Simple

Noir

18.6 A

SC18G

10.2 mm

Diamètre du raccord au refoulement [mm]	6.2 mm
Diamètre du raccordement du traitement [mm]	6.2 mm
Désignation du modèle	Compresseur
Emballage (format)	Emballage industriel
Faible valeur de plage de tension à 50 Hz [V]	187 V
Faible valeur de plage de tension à 60 Hz [V]	198 V
Faible valeur de tension nominale à 50 Hz [V]	208 V
Faible valeur de tension nominale à 60 Hz [V]	220 V
Fluides	R134a
Fréquence [Hz]	50/60
Hauteur de la base [mm]	213 mm
Hauteur du raccordement de refoulement [mm]	110 mm
Hauteur raccordement aspiration [mm]	193 mm
Hauteur totale [mm]	219 mm
LRA HST [A]	18.6 A
Matériel du raccord au process	Acier cuivré
Matériel du raccord d'aspiration	Acier cuivré
Matériel du raccord de refoulement	Acier cuivré
Niveau d'énergie de l'application	Compresseur universel
Nombre de phases (compresseur)	1
Nombre de phases (ventilateur)	1
Norme d'approbation	CE EN 60335-2-34 avec Annexe AA
Notes concernant le raccord de refoulement	Capuchon en aluminium
Notes concernant le raccordement au process	Capuchon en aluminium
Notes concernant le raccordement à l'aspiration	Capuchon en aluminium
N° de modèle	SC18G
N° de schéma	8258
Oil type	POE
Phase	1
Puissance frigorifique nominale 60 kBTU/h	6.06 kBtu/h
Puissance frigorifique nominale à 60 Hz	1.8 kW
Quantité d'huile [cm ³]	600 cm ³
Quantité par emballage	80
raccord de refoulement équerre [°]	37 °
raccord d'aspiration équerre [°]	37 °
Raccordement de process équerre	37 °
Régulation de la puissance	Vitesse fixe
Résistance de l'enroulement auxiliaire (enroulement de démarrage) pour compresseurs monophasés [ohm]	14.1 Ohm
Résistance de l'enroulement principal pour compresseurs monophasés [Ohm]	3.7 Ohm
Technique de la marque	Compresseur à pistons
Technologie	Piston
Température d'enroulement max. continue [°C] [Max]	125 °C
Température de l'enroulement à court terme [°C] [Max]	135 °C
Tension 50 Hz [V]	220 V

Tension 50 Hz [V] [max.]	240 V
Tension 60 Hz [V]	220 V
Tension 60 Hz [V] [max.]	240 V
Type	SC
Type de moteur	CSIR
Type de socle	Universel
Utilisation de tronçon	Réfrigération LT Réfrigération MT
Valeur du condensateur A	10 μ F
Valeur du condensateur B	80 μ F
Valeur élevée de plage de tension à 50 Hz [V]	254 V
Valeur élevée de plage de tension à 60 Hz [V]	254 V
Valeur élevée de tension nominale à 50 Hz [V]	230 V
Valeur élevée de tension nominale à 60 Hz [V]	230 V
Vitesse de rotation à 50 Hz [rpm]	2900 rpm
Vitesse de rotation à 60 Hz [rpm]	3500 rpm
Volume balayé [cm ³]	17.69 cm ³
Volume de gaz libre [cm ³]	1460 cm ³
Économiseur	No

Documents

Type de document	Country	Langue	Titre
	France	Français	
	Afrique du Sud	Anglais	
	Allemagne	Français	
	Australie Autriche	Allemand	
	Belarus Belgique	Anglais	
	Brazil Bulgarie	Arabe	
	Canada Chili Chine (continentale)	Bulgare	
	Colombie Corée du Sud	Chinois	
	Croatie	Coréen	
	Danemark	Croate	
	Emir.arab.unis	Danois	
	Espagne Estonia	Espagnol	
	Finlande Grande Bretagne	Estonien	
	Grèce	Finnois	Grec
	Hongrie Inde + Sikkim	Hindi	
	Indonésie	Hongrois	
	Ireland Islande	Hébreu	
	Israël Italie	Indonésien	
	Japon Kazakhstan	Islandais	
	Lettonie Lithuania	Italien	Titre
	Macedonia Malaisie	Japonais	
	Mexique N. Zélande	Kazakh	
	Norvège Pays-Bas	Letton	
	Philippines	Lituanien	
	Pologne Portugal	Norvégien	
	Roumanie Russian Federation	Néerlandais	
	Rép. tchèque Saudi Arabia	Polonais	
	Serbia	Portugais	
	Singapour	Roumain	
	Slovaquie Slovénie	Russe	Serbe
	Suisse Suède	Slovaque	
	Taiwan, Chine	Slovène	
	Thailand Tunisie	Suédois	
	Turquie Ukraine	Suédois	
	USA Viêt Nam	Tchèque	Thaï
	Vénézuéla	Turc	
		Ukrainien	
		Vietnamien	
Fiche technique	France	Français	220V Hermetic Compressors – R12 – R22 – R205 AI32443441788901-FR0101 1984 KB
Fiche technique	France	Français	Listing Compresseur Secop AI302136056984fr-FR0101 253 KB
Guide d'installation	France	Français	Instructions SC Compressors (external Protector) AN00008643706001-000401 124 KB
Guide d'installation	France	Français	Instructions SC Twin Compressors AN00008643707201-000101 183 KB

Type de document	Country	Langue	Titre
	France		
	Afrique du Sud	Langue	
	Allemagne	Français	
	Australie Autriche	Allemand	
	Belarus Belgique	Anglais	
	Brazil Bulgarie	Arabe	
	Canada Chili Chine	Bulgare	
	(continentale)	Chinois	
	Colombie Corée du	Coréen	
	Sud Croatie	Croate	
	Danemark	Danois	
	Emir.arab.unis	Espagnol	
	Espagne Estonia	Estonien	
	Finlande Grande	Finnois Grec	
	Bretagne Grèce	Hindi	
	Hongrie Inde +	Hongrois	
	Sikkim Indonésie	Hébreu	
	Ireland Islande	Indonésien	
	Israël Italie	Islandais	
	Japon Kazakhstan	Italien	Titre
	Lettonie Lithuania	Japonais	
	Macedonia Malaisie	Kazakh	
	Mexique N. Zélande	Letton	
	Norvège Pays-Bas	Lituanien	
	Philippines	Norvégien	
	Pologne Portugal	Néerlandais	
	Roumanie Russian	Polonais	
	Federation Rép.	Portugais	
	tchèque Saudi	Roumain	
	Arabia Serbia	Russe Serbe	
	Singapour	Slovaque	
	Slovaquie Slovénie	Slovène	
	Suisse Suède	Suédois	
	Taiwan, Chine	Tchèque Thaï	
	Thailand Tunisie	Turc	
	Turquie Ukraine	Ukrainien	
	USA Viêt Nam	Vietnamien	
	Vénézuéla		

**Matériel
promotionnel**

France

Français

Refrigerant Circuit

AV00008642183800-000402
463 KB

Compresseur Danfoss SC18G - R134a

Cylindrée = 17.69 CM3

APPLICATIONS = HP; BP; MP

Moteur = CSIR

220-240V 50/60Hz



Design

Displacement	cm ³	17.69
Oil quantity	cm ³	600 (550 on comp. with oil cooler)
Maximum refrigerant charge	g	1300
Free gas vol. in compressor	cm ³	1460
Weight without electrical equipment	kg	13.7

Motor

Motor size	watt	495
LRA (rated after 4 sec. UL984) HST	A	18.6
Cut-in current HST	A	18.6
Resistance, main and start winding (25°C)	Ω	3.7/14.1
Approvals		EN 60335-2-34, CCIB

Dimensions

104G8830 104G8820 104G8822

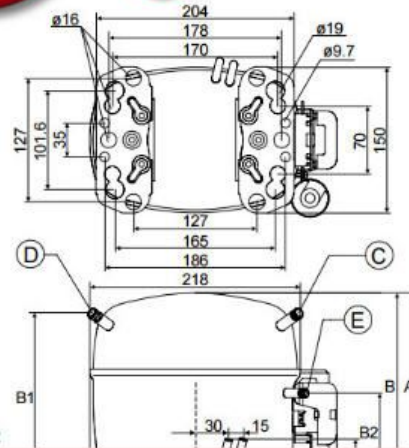

Private Picture Copyright : WWW.MBSM.PRO

R134a	refrigerant	605076	رقم القطعة
HP 1/2	power	SC18G	type
cm ³ 17.7	cylinder capacity	W 495	power input
V 220-240	voltage	CSIR	motor system
W 844	power at -10°C	mm 219	height
W 1343	power at 0°C	W 1074	power at -5°C
W -	power at -30°C	W 1655	power at +5°C
W 485	power at -20°C	W 348	power at -25°C
W 2014	power at +10°C	W 649	power at -15°C
HMBP	application	ASHRAE	test method
kg 13.7	weight	Hz 50	frequency



Private Picture Copyright : WWW.MBSM.PRO

Visuels

Mbsm_dot_pro_private_PDF_SC18GTélécharger



Private Picture Copyright : WWW.MBSM.PRO

Types of Electrical Motors, RSIR, CSIR, RSCR, CSR, PTC, NTC, LST, HST, MBP, HBP, LBP

Category: compressor,Files

written by www.mbsm.pro | 12 December 2021

Types of Electrical Motors

RSIR (Resistance Start-Induction Run)

LST motor. No capacitors. Auxiliary winding is disconnected after start up. Standard energy efficiency.

CSIR (Capacitor Start-Induction Run)

HST motor. With starting capacitor. Auxiliary winding is disconnected after start up. Standard efficiency.

RSCR (Resistance Start-Capacitor Run)

LST motor. With running capacitor. Auxiliary winding remains connected after start up. Used for high efficiency in small capacity compressors (particularly in household refrigeration)

CSR (Capacitor Start and Run)

HST motor. Two capacitors (starting and running). Auxiliary winding remains connected after start up. Used for high efficiency in small compressors and for size reduced size motors in compressors with comparatively large displacements.



Private Picture Copyright : WWW.MBSM.PRO

Types of Electrical Motors

RSIR (Resistance Start-Induction Run)

LST motor. No capacitors. Auxiliary winding is disconnected after start up. Standard energy efficiency.

CSIR (Capacitor Start-Induction Run)

HST motor. With starting capacitor. Auxiliary winding is disconnected after start up. Standard efficiency.

RSCR (Resistance Start-Capacitor Run)

LST motor. With running capacitor. Auxiliary winding remains connected after start up. Used for high efficiency in small capacity compressors (particularly in household refrigeration)

CSR (Capacitor Start and Run)

HST motor. Two capacitors (starting and running). Auxiliary winding remains connected after start up. Used for high efficiency in small compressors and for size reduced size motors in compressors with comparatively large displacements

Types of Electrical Motors

RSIR (Resistance Start-Induction Run)

LST motor. No capacitors. Auxiliary winding is disconnected after start up. Standard energy efficiency.

CSIR (Capacitor Start-Induction Run)

HST motor. With starting capacitor. Auxiliary winding is disconnected after start up. Standard efficiency.

RSCR (Resistance Start-Capacitor Run)

LST motor. With running capacitor. Auxiliary winding remains connected after start up. Used for high efficiency in small capacity compressors (particularly in household refrigeration)

CSR (Capacitor Start and Run)

HST motor. Two capacitors (starting and running). Auxiliary winding remains connected after start up. Used for high efficiency in small compressors and for size reduced size motors in compressors with comparatively large displacements.



Private Picture Copyright : WWW.MBSM.PRO

Type of starting device

Current relay – (electromechanical). RSIR/CSIR motors and CSR low/medium-power motors with NTC (the NTC is connected in series with the starting capacitor and the main purpose is to reduce the current peaks in the relay contacts)

Potential relay – (electromechanical). CSR high-power motors.

PTC – (Positive Temperature Coefficient), the resistance increases with the temperature. Device only with RSIR or RSCR motors in the (Small L, B), L and P ranges.

NTC – (Negative Temperature Coefficient), the resistance decreases with the temperature. Used in some CSR in order to reduce dimensions and components.

Type of starting device

Current relay – (electromechanical). RSIR/CSIR motors and CSR low/medium-power motors with NTC (the NTC is connected in series with the starting capacitor and the main purpose is to reduce the current peaks in the relay contacts)

Potential relay – (electromechanical). CSR high-power motors.

PTC – (Positive Temperature Coefficient), the resistance increases with the temperature. Device only with RSIR or RSCR motors in the (Small L, B), L and P ranges.

NTC – (Negative Temperature Coefficient), the resistance decreases with the temperature. Used in some CSR in order to reduce dimensions and components.

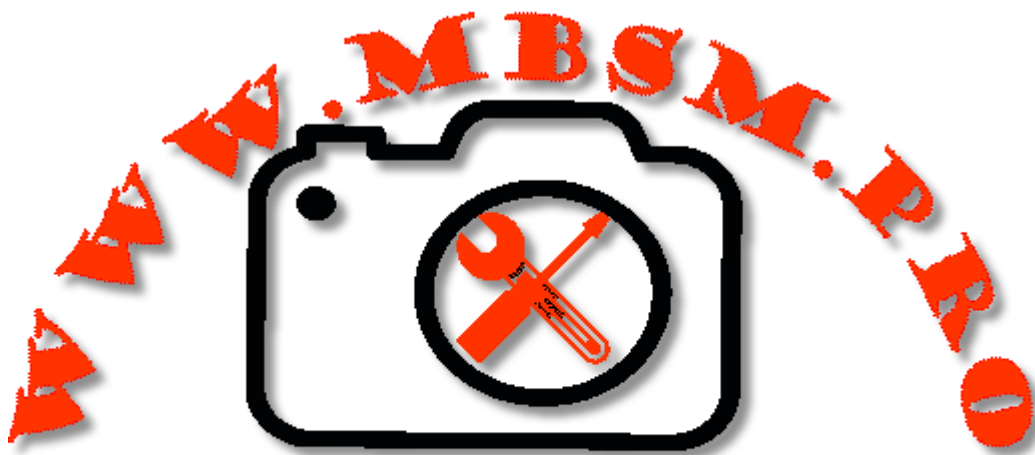

Private Picture Copyright : WWW.MBSM.PRO

Type of torque

LST – Low Starting Torque – Systems with capillary tube or balanced pressures at start up.

HST – High Starting Torque – Systems with expansion valve or capillary tube, with unbalanced pressures at start up.

Type of torque

LST – Low Starting Torque – Systems with capillary tube or balanced pressures at start up.

HST – High Starting Torque – Systems with expansion valve or capillary tube, with unbalanced pressures at start up.

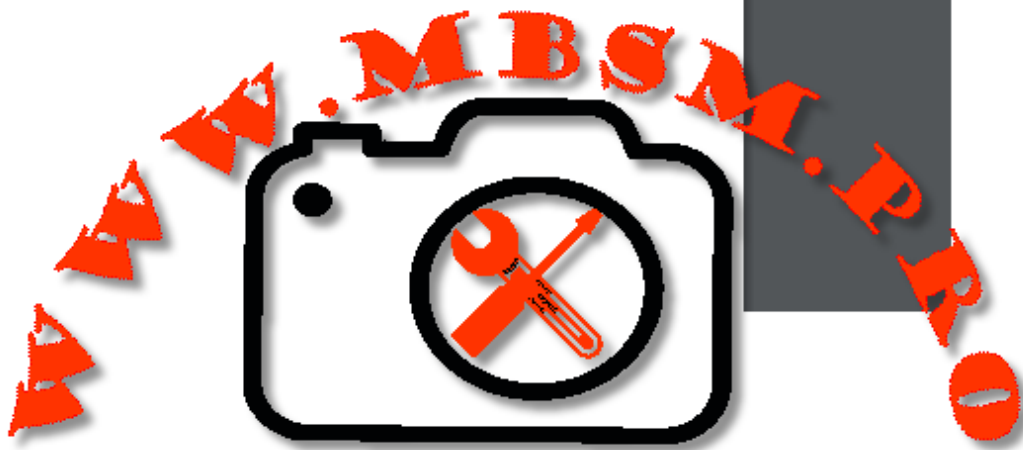



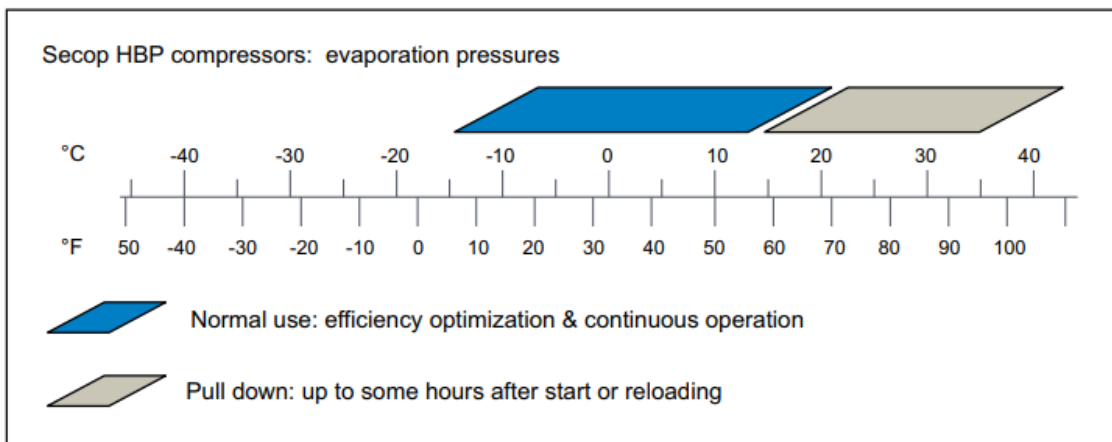

Private Picture Copyright : WWW.MBSM.PRO

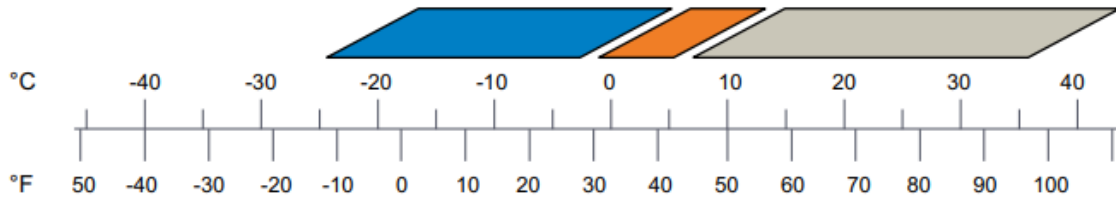

Private Picture Copyright : WWW.MBSM.PRO

Secop MBP compressors: evaporation pressures







-  Normal use: efficiency optimization & continuous operation
-  High load: continuous operation
-  Pull down: up to some hours after start or reloading

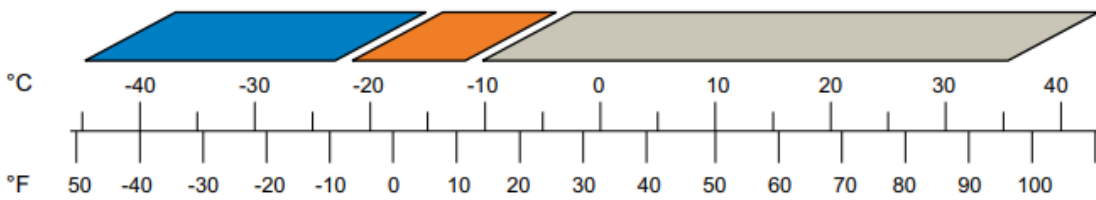

Private Picture Copyright : WWW.MBSM.PRO

Secop LBP compressors: evaporation pressures



-  Normal use: efficiency optimization & continuous operation
-  High load: continuous operation
-  Pull down: short time operation (<60min.) after start or defrost



Private Picture Copyright : WWW.MBSM.PRO

ALL COMPRESSOR HERMÉTIC EMBRACO IN ONE FILE

Category: compressor

written by www.mbsm.pro | 12 December 2021

COMPRESORES R404A/ R452A BAJA TEMPERATURA. MONOFÁSICAS 220V

MODELO	CM3	EXP	C.V	INT (A)	REFR COMP	MOTOR	TEMP. DE EVAPORACIÓN			PRECIO
							-10°C	-25°C	-30°C	
EMT2117GK	4,50	C	1/4	1,15	F	CSIR	408	210	164	143,00
EMT2121GK	5,20	C	1/3	1,33	F	CSIR	487	258	204	146,00
EMT2125GK	5,96	C-V	1/3	1,57	F	CSIR	562	301	238	158,00
EMT2130GK	6,76	C-V	1/2	1,70	F	CSIR	605	326	257	165,00
NEU2140GK	8,78	C-V	1/2	2,63	F	CSIR	801	421	326	182,00
NEU2155GK	12,11	C-V	3/4	3,79	F	CSIR	1067	557	432	201,00
NEU2168GJ	14,28	C-V	3/4	3,48	F	CSIR	1213	642	496	240,00
NEU2178GK	16,80	C-V	1	4,27	F	CSIR	1416	753	586	287,00
NT2180GK	20,44	C-V	1	3,12	F	CSIR	1573	814	625	330,00
NT2192GK	22,40	C-V	1	4,92	F	CSIR	1693	865	669	365,00
NT2192GK(*)	22,40	C-V	1	4,92	F	CSIR	1693	865	669	345,00
NT2210GK	26,20	C-V	1 1/2	6,43	F	CSIR	2041	1052	804	375,00
NT2210GK(*)	26,20	C-V	1 1/2	6,43	F	CSIR	2041	1052	804	355,00
NT2212GK	27,78	C-V	1 1/2	5,30	F	CSIR	2174	1125	876	380,00
NJ2212GK	34,37	C-V	1 1/2	5,80	F	CSIR	2487	1276	961	419,00
NJ2212GK(*)	34,37	C-V	1 1/2	5,80	F	CSIR	2487	1276	961	394,00



Private Picture Copyright : WWW.MBSM.PRO

EMT22HLP 3,00 C 1/12 0,44 S RSIR 151 69 50 98,00
 EMT36HLP 3,97 C 1/10 0,56 S RSIR 203 94 71 102,00
 EMY3111Z 4,85 C 1/8 0,71 S RSIR 247 117 86 105,00
 EMT49HLP 5,56 C 1/6 0,76 S RSIR 274 131 98 111,00
 EMY3115Z 6,76 C 1/6 0,99 S RSIR 341 158 117 112,00
 NEK1116Z 7,37 C 1/5 0,60 S RSIR 367 172 126 129,00
 NEK1118Z 8,39 C 1/4 0,74 S RSIR 417 195 144 133,00
 NE2121Z 9,26 C/V 1/4 1,41 F CSIR 465 217 163 172,00
 NE2130Z 12,11 C/V 1/3 2,07 F CSIR 613 298 227 186,00
 NE2134Z 14,28 C/V 1/3 2,30 F CSIR 662 313 234 190,00
 NEK2140Z 16,80 C/V 1/2 2,35 F CSIR 801 377 284 207,00
 MODELO CM3 EXP C.V INT
 (A)
 REFR
 COMP MOTOR TEMP. DE EVAPORACIÓN PRECIO +5°C 0°C -5°C -10°C
 EMT37HDP 3,40 C 1/8 0,85 S RSIR 343 245 228 181 113,00
 EMT45HDR 3,97 C 1/8 0,95 S CSIR 402 284 229 184 121,00
 EMT50HDP 4,50 C 1/6 1,05 S RSIR 456 374 303 242 120,00
 EMT6144Z 5,20 C/V 1/5 1,38 F RSIR 549 395 367 294 123,00
 EMT6160Z 6,76 C/V 1/4 1,74 F RSIR 696 504 469 377 127,00
 EMT6170Z 7,69 C/V 1/4 2,03 F RSIR 771 559 522 418 134,00
 NEU6187Z 10,00 C/V 1/3 2,61 F RSIR 918 654 600 477 151,00
 NEU6210Z 12,12 C/V 1/3 3,15 F RSIR 1170 955 770 615 163,00
 NEU6212Z 14,30 C/V 1/2 3,90 F RSIR 1365 1114 894 707 174,00
 NEU6214Z 16,80 C/V 1/2 4,21 F RSIR 1569 1292 1047 836 199,00
 NT6217Z 20,44 C/V 3/4 4,73 F RSIR 1795 1256 1173 938 292,00
 NT6220Z 22,37 C/V 3/4 5,24 F RSIR 1897 1554 1260 1010 323,00
 NJ6220Z 26,11 C/V 3/4 5,71 F RSIR 2202 1780 1419 1104 386,00
 NJ6220Z () 26,11 C/V 3/4 5,71 F RSIR 2202 1780 1419 1104 379,00 NJ6226Z 34,38
 C/V 1 5,95 F CSR 2852 2340 1892 1497 439,00 NJ6226Z () 34,38 C/V 1 5,95 F CSR
 2852 2340 1892 1497 410,00

COMPRESORES R404A/ R452A BAJA TEMPERATURA. MONOFÁSICAS 220V

MODELO	CM3	EXP	C.V	INT (A)	REFR COMP	MOTOR	TEMP. DE EVAPORACIÓN			PRECIO
							-10°C	-25°C	-30°C	
EMT2117GK	4,50	C	1/4	1,15	F	CSIR	408	210	164	143,00
EMT2121GK	5,20	C	1/3	1,33	F	CSIR	487	258	204	146,00
EMT2125GK	5,96	C-V	1/3	1,57	F	CSIR	562	301	238	158,00
EMT2130GK	6,76	C-V	1/2	1,70	F	CSIR	605	326	257	165,00
NEU2140GK	8,78	C-V	1/2	2,63	F	CSIR	801	421	326	182,00
NEU2155GK	12,11	C-V	3/4	3,79	F	CSIR	1067	557	432	201,00
NEU2168GJ	14,28	C-V	3/4	3,48	F	CSIR	1213	642	496	240,00
NEU2178GK	16,80	C-V	1	4,27	F	CSIR	1416	753	586	287,00
NT2180GK	20,44	C-V	1	3,12	F	CSIR	1573	814	625	330,00
NT2192GK	22,40	C-V	1	4,92	F	CSIR	1693	865	669	365,00
NT2192GK(*)	22,40	C-V	1	4,92	F	CSIR	1693	865	669	345,00
NT2210GK	26,20	C-V	1 1/2	6,43	F	CSIR	2041	1052	804	375,00
NT2210GK(*)	26,20	C-V	1 1/2	6,43	F	CSIR	2041	1052	804	355,00
NT2212GK	27,78	C-V	1 1/2	5,30	F	CSIR	2174	1125	876	380,00
NJ2212GK	34,37	C-V	1 1/2	5,80	F	CSIR	2487	1276	961	419,00
NJ2212GK(*)	34,37	C-V	1 1/2	5,80	F	CSIR	2487	1276	961	394,00



Private Picture Copyright: WWW.MBSM.PRO

Mbsm_dot_pro_private_PDF8compresores_hermeticos_embraco_2019Télécharger

Whirlpool, Aspera, NE2125E, LBP, capacitive, start inductive run, hermetic compressor, R22, 1/4Hp++ or 1/3Hp-

Category: compressor

written by www.mbsm.pro | 12 December 2021

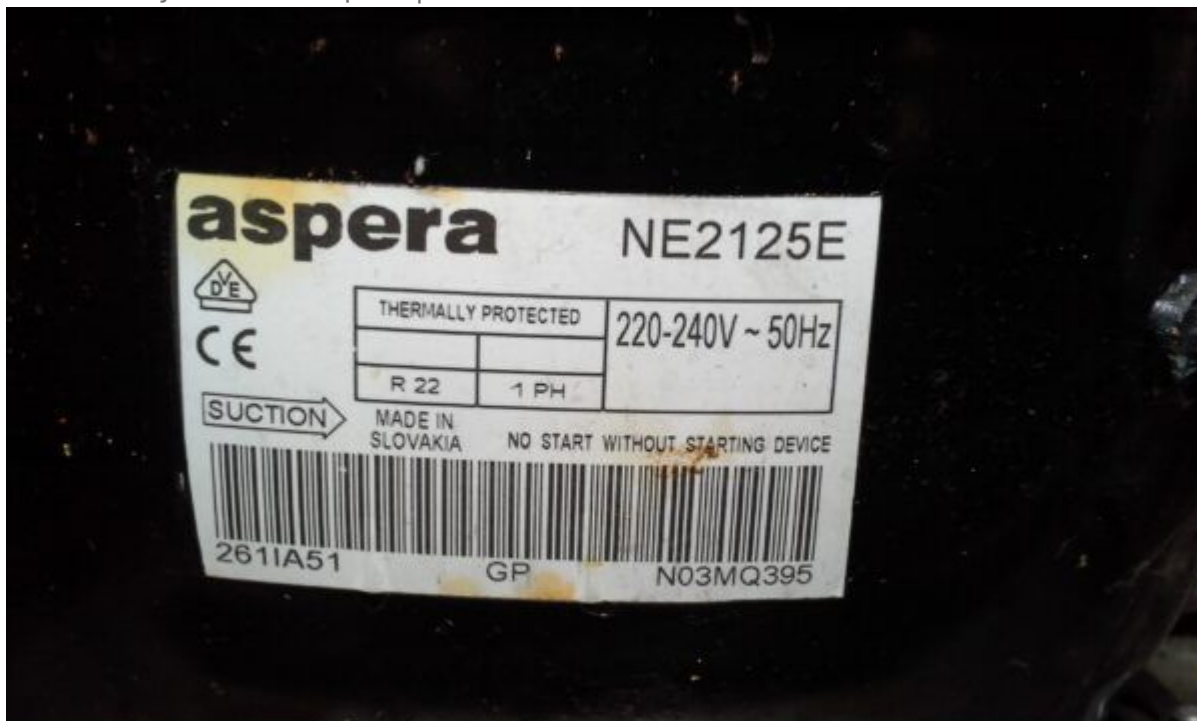

Private Picture Copyright: WWW.MBSM.PRO

compressor Aspera NE2125E, LBP – R22, 220-240V / 1 / 50Hz, stroke volume 8.78 cm3, LRA 11.0A, motor type CSIR, capillary tube / expansion valve operation, oil AB 46. Cooling capacity measured for condensation temperature of: 45 ° C, Measurement conditions: ASHRAE

Unfortunately the compressor is no longer available.

If you would like an offer for an identical alternative, please email us or give us a short call, we will prepare an offer for you. Cooling capacity (W) at To

- 10 ° C - 15 ° C - 20 ° C - 25 ° C - 30 ° C

651 517 401 304 226

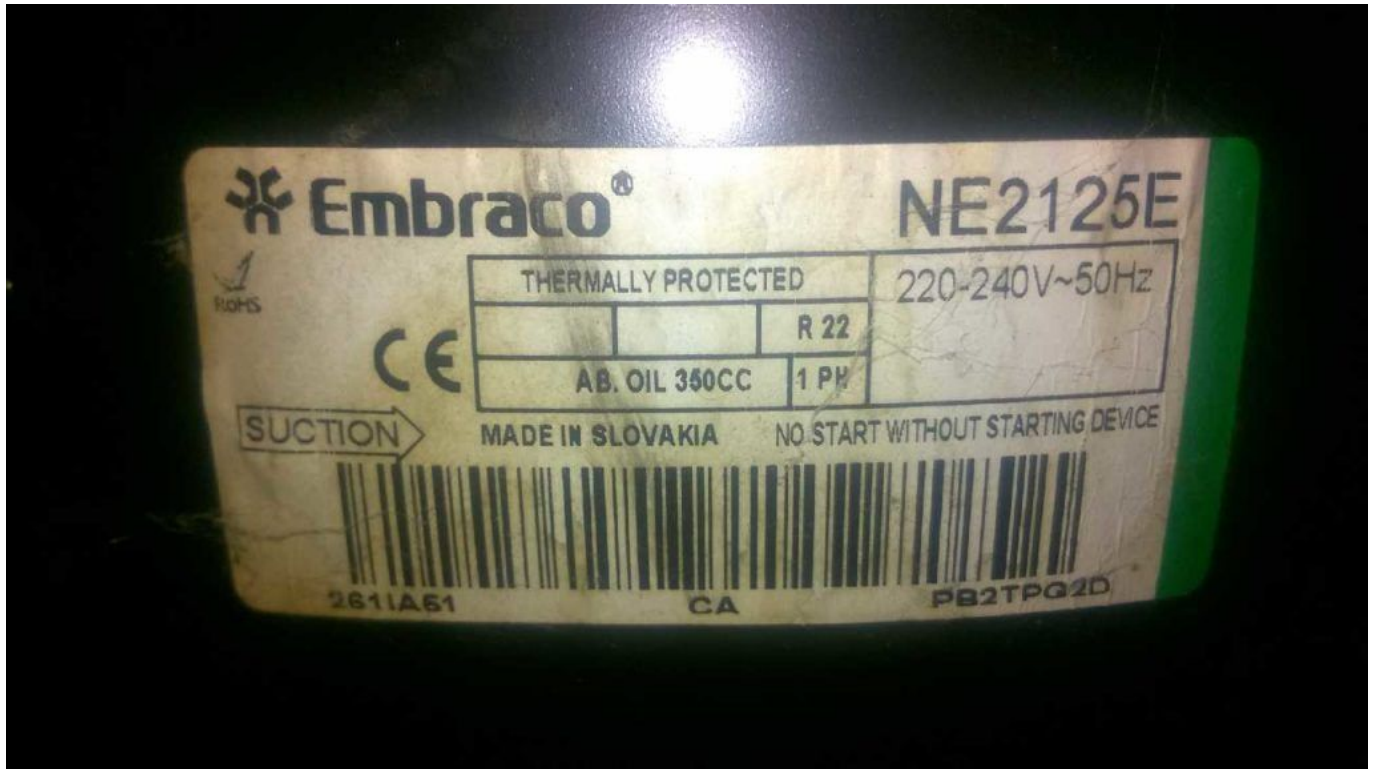

R22 - LBP Applications

COMPRESSOR	FREQUENCY	DIMENSION	
		(from -30°C to -5°C evap. temp.)	-
NE2125E	50 Hz	0.91 mm I.D. × 3.2 m	-
	60 Hz	0.91 mm I.D. × 2.85 m	-
NE2134E	50 Hz	0.91 mm I.D. × 2.8 m	-
	60 Hz	0.91 mm I.D. × 2.5 m	-
T2140E	50 Hz	0.91 mm I.D. × 2.6 m	-
	60 Hz	0.91 mm I.D. × 2.3 m	-
T2155E	50 Hz	1.20 mm I.D. × 3.9 m	-
	60 Hz	1.20 mm I.D. × 3.5 m	-
T2168E	50 Hz	1.20 mm I.D. × 3.3 m	-
	60 Hz	1.20 mm I.D. × 2.8 m	-
NJ2178E	50 Hz	1.20 mm I.D. × 3.0 m	-

PictureS Mbsm Dot Pro : www.mbsm.pro

Private Picture Copyright : WWW.MBSM.PRO

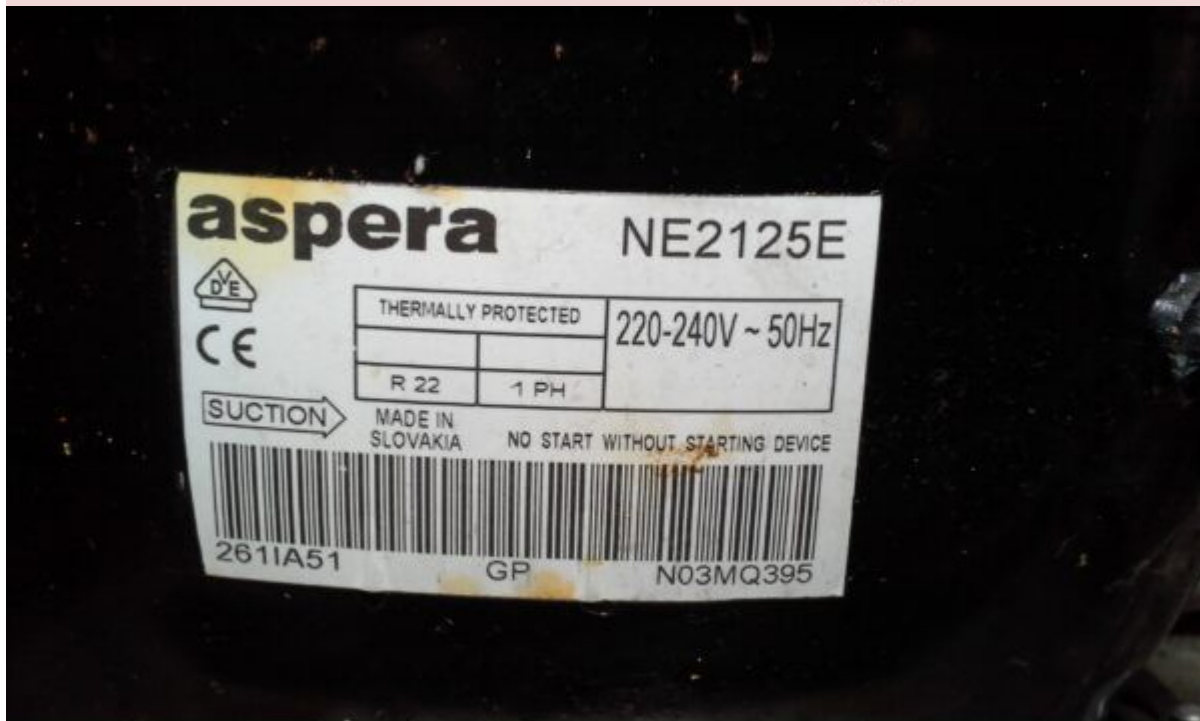

Private Picture Copyright : WWW.MBSM.PRO



Private Picture Copyright : WWW.MBSM.PRO



Private Picture Copyright : WWW.MBSM.PRO



Private Picture Copyright : WWW.MBSM.PRO









Private Picture Copyright: WWW.MBSM.PRO

Mbsm_dot_pro_private_PDF_ne2125e-Embraco_VerdichterTélécharger

Shipping Class	Default
Scope Of Application	LBP
Delivery Time	2-3 Weeks
Stock Availability	In Stock
Type	Reciprocating Piston
Condensation Temperature	45 ° C
Manufacturer	Aspera
Manufacturer No.	NE2125E
Power In Hp	1/4 +
Starting Torque	HST
Stroke Volume In Cm3	8.78
Measurement Conditions	Ashrae
Refrigerant	R22
Oil Type	IS046
Series	NE
Condensing Units Compressors	Compressor

Tension	220-240V
Weight In Kg	10.4

Compressor, NL7.3FT, SECOP, 105G6726, DANFOSS, 6726, 105G, 105 G 6726, 105G 6726, 1/5 HP, 180W, LBP, Zanussi, Kiriazi Electric Company, TGV 335L, NO FROST, TSV 320L, FC 83L , R134A, 125G, 220-240V 50Hz, CSIR

Category: compressor

written by www.mbsm.pro | 12 December 2021

KIRIAZI



CE



ELECTRIC
COMPANY

®

Product	No Frost Refrigerator	Class	T
Model	E 335N/3	Current / Amp.	1.1/~
Rated Voltage	220-240V/50HZ	Refrigerant	R 134a 125g
Rated input of lamp	1 x 25 w	Total Gross Volume	335 L
Ins : Basic	Type II IPX4	Total Storge Volume	320 L
Freezing Capacity	4 kg/24hr	Freezer Capacity	83L
ES 6000 / 2008		Tow Door Ref.	
ES 3793 / 2006			
Serial Number		Made in Egypt	



● ○ REDMI NOTE 8
○ ∞ AI QUAD CAMERA

Private Picture Copyright : WWW.MBSM.PRO

R134a is a low pressure refrigerant, very efficient for high temperature applications.

This makes it ideal in air conditioning applications that may leak refrigerant like car air conditioning.

Now it is being phased out because of its high global warming potential and replaced by R134

R404a is a high pressure refrigerant ideal for applications in low and medium temperature.

You want low pressure refrigerants in household applications like refrigerators that may be inside kitchens with (possible) high ambient temperature, so you make sure nothing will blow up. For the same reason you want R134a in your car air conditioning.

R404a instead has pressures slightly above atmospheric in low temperature applications where R134a would have negative pressures and its heat transmission coefficients would be much lower.

Type de gaz	App	HP	Watt	Modèle	TL
R134A	LBP	1/6	134	TLY5.1FK	
R134A	LBP	1/4	183	TLES7FT.4	

R134A	LBP	1/5	156	NL6FT.2	
R134A	LBP	1/5	185	NL7.3FT (RSIR)	
R134A	LBP	+ 1/4	219	NL9FT.2 (RSIR)	
R134A	LBP	1/4	185	NL7.3FT (CSIR)	
R134A	LBP	+ 1/4	219	NL9FT.2 (CSIR)	NL
R134A	LBP	1/3	284	NL10FT	
R134A	MBP	1/3	621	NL11MF	
R404A	LBP	1/3	433	NL7CLX	
R404A	LBP	1/3	471	NL8.4CLX	
R134A	LBP	1/4	187	NLY6F	
R134A	LBP	+ 4 /	213	NLY7F	
		(1)			
R134A	LBP	1/3	237	NLY9FK	
R600A	LBP	+ 1/4	227	NLE13KTK.2	
R600A	LBP	1/3	253	NLE15KTK.2	
R600A	LBP	+ 1/4	225	NLX13KK.3	
R600A	LBP	1/3	254	NLX15KK.3	

R134A	LBP / MBP / 1/3 HBP	264	SC12G	
R134A	LBP / MBP / 1/2 HBP	392	SC18G	
R134A	LBP / MBP / 3/4 HBP	456	SC21G	SC
R134A	MBP 3/4	1073	SC21MFX	
R134A	LBP 3/4	567	SC21FTX	
R404A	LBP 1	1033	ST21CL	
R404A	LBP 1	986	SC18CLX.2	
R404A	MBP 1/2	359/650	SC15MLX	
R404A	MBP 7/8	762/1584	SC18MLX	

KIRIAZI



CE

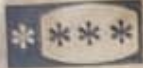

ELECTRIC
COMPANY

®

Product	No Frost Refrigerator	Class	T
Model	E 335N/3	Current / Amp.	1.1/~
Rated Voltage	220-240V/50HZ	Refrigerant	R 134a 125g
Rated input of lamp	1 x 25 w	Total Gross Volume	335 L
Ins : Basic	Type II IPX4	Total Storge Volume	320 L
Freezing Capacity	4 kg/24hr	Freezer Capacity	83L
ES 6000 / 2008		Tow Door Ref.	
ES 3793 / 2006			
Serial Number		Made in Egypt	



REDMI NOTE 8
AI QUAD CAMERA

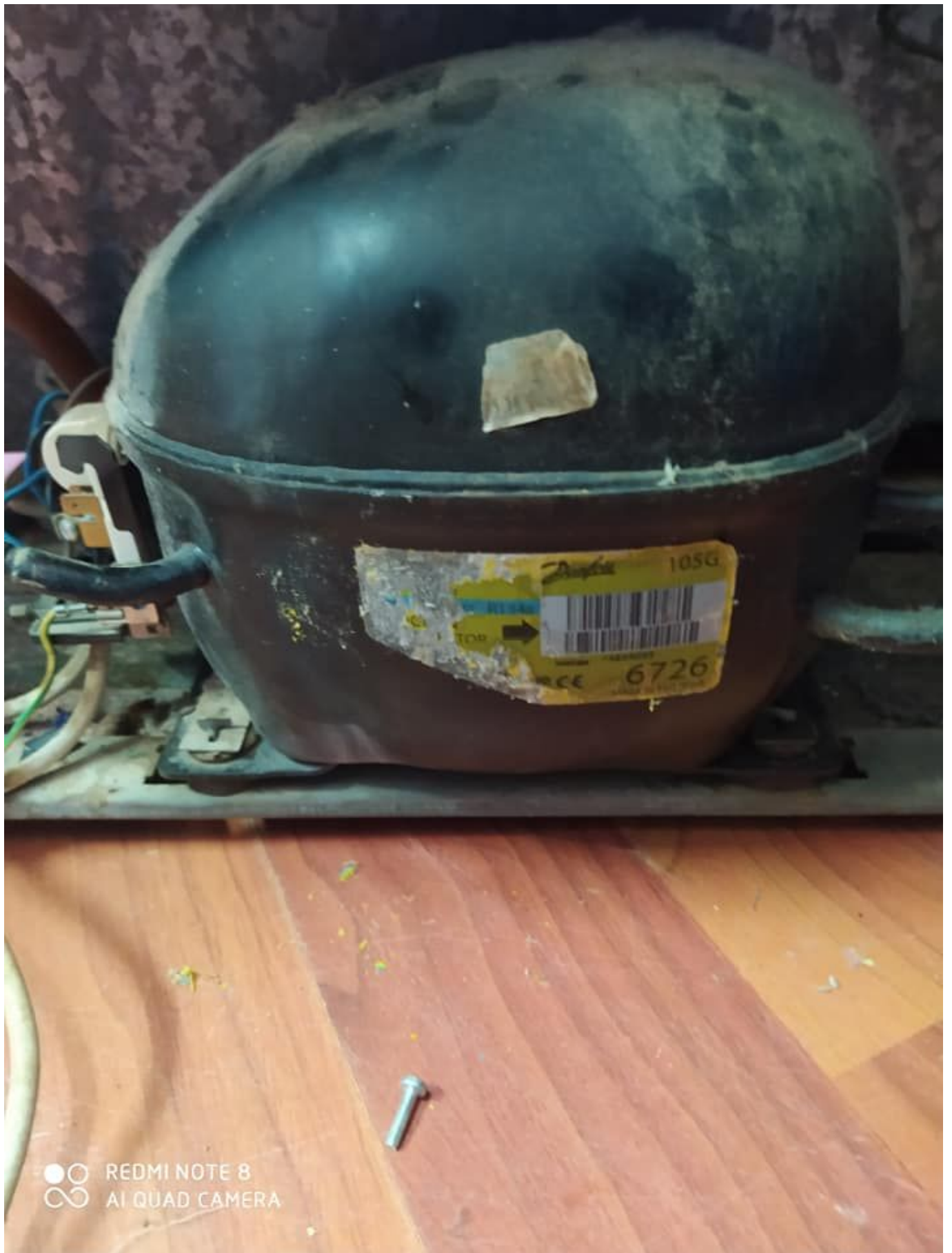

REDMI NOTE 8
AI QUAD CAMERA

Private Picture Copyright : WWW.MBSM.PRO

Mbsm_dot_pro_private_PDF_NL7.3FTTélécharger
Mbsm_dot_pro_private_PDF_nl73ft_105g6731_r134a_220v_50hz_11-2011_desd406c102Télé
charger

Refrig	Applic	oil cooling	Evaporating temperature [°C]											Evaporating tem					
			-35	-30	-25	-20	-15	-10	-5	0	5	10	15	-25	-10				
R134a	LBP		1/20	14	26	40	56	74	95								60	86	
		PL50F	101G0220	1/20	14	26	40	56	74	95								60	86
		TL53FT	102G4324	1/16	21	34	50	69	92	120								62	93
		TL54FT	102G4424	1/10	27	43	63	88	117	152								88	123
		TL55FT	102G4524	1/8+	48	71	98	131	170	216								114	165
		TL55.7FT.3	102G4615	1/6	66	90	120	156	200	253								120	170
		TL56.5FT.3	102G4703	1/5			136												139
		NL6FT	105G6628	1/6	60	84	115	152	198	253								123	184
		NL6.1FT	105G6620	1/6	60	84	115	152	198	253								123	184
		NL7FT	105G6728	105G6738	1/5	71	100	136	181	235	299							145	220
		NL7.3FT	105G6726		1/5	71	100	136	181	235	299							145	220
		NL8.4FT	105G6865		1/4	87	120	162	213	275	350							169	252
		NL9FT	105G6828	105G6838	1/4	87	120	162	213	275	350							169	252
		NL10FT	105G6829	105G6839	1/3	113	158	213	281	361	455							215	316
		NLE7.3FT	105G6710		1/4	92	118	154	201	258	325							148	221
		SC12FT	104G8205	104G8215	1/3	103	163	233	314	408	517	645						265	380
		SC15FT	104G8505		1/2	126	197	280	376	489	620	772						311	451
		SC18FTX	104G8805		5/8	144	229	325	437	567	719	896						365	517
		SC21FTX 50Hz	104G8105		3/4	192	296	415	553	713	901	1119						428	613
		SC21FTX 60Hz	104G8106		3/4	240	345	470	620	800	1012	1262						475	707
		TL2.5G	102G4251		1/12	11	23	36	51	69	90	116	145	179	219	264		60	84
		TL3G	102G4350		1/12	25	41	59	81	106	136	170	211	258	312		66	96	
		TL4G	102G4452		1/8	41	58	80	107	140	180	226	280	342	413		83	118	
		TL5G	102G4550		1/6	56	79	107	139	178	224	278	341	414	497		100	149	
	FR6G	103G6660		1/5	48	83	124	171	226	290	365	452	552			109	172		
	FR7.5G	103G6680	103G6690	1/5	62	99	142	193	254	325	408	505	618			126	194		
	FR8.5G	103G6780	103G6790	1/4	85	123	171	228	298	381	478	592	722			151	231		
	FR10G	103G6880	103G6890	1/4	92	136	188	250	324	412	516	638	779			179	265		
	FR11G	103G6980		1/3	115	170	233	307	395	501	628	780				202	317		
	TL6.5MF	102G4781		1/4			174	219	279	349	425	520						202	
	NL6.1MF	105G6660		1/5			141	189	245	312	390	482	588	709				187	
	NL7.3MF	105G6772		1/4			179	236	304	385	480	591	719	867				227	
	NL8.4MF	105G6879		1/4+			213	277	353	445	553	679	825	994				261	
	NL10MF	105G6885		1/3			266	346	441	554	687	843	1023	1231				323	
	NLE10MF	105G6888		1/3	88	137	194	262	343	440	554	688	845				198	308	
	NL11MF	105G6151		3/8			292	380	485	609	756	927	1125	1354				360	
	SC10G	104G8000		5/16	23	60	113	183	268	369	486	618	764	925	1100		181	290	
	SC12G	104G8240	104G8250	3/8	65	113	175	252	348	464	603	768	960	1182	1437		227	355	
	SC15G	104G8520	104G8530	1/2			164	290	424	568	728	908	1110	1340	1600		233	440	
SC18G	104G8820	104G8830	1/2+			283	394	526	684	870	1087	1337	1624	1950		331	507		

model	watt	HP	LBP/MBP	نوع گاز	توضیحات
SC12G	246	1/3	LBP/MBP	134	
SC18G	392	1/2	LBP/MBP	134	
SC21G	456	3/4	LBP/MBP	134	
SC21MFX	1073	3/4	MBP	134	فیلترین SC21G
SC21FTX	567	3/4	LBP	134	فیلترین SC21G
SC12CL	629		LBP	404	
SC15CL	782		LBP	404	
SC18CLX.2	986		LBP	404	
TLS5FT(PTC)	134	1/6	LBP	134	
TLES5.7FT(PTC)	163	1/5	LBP	134	
TLES6.5FT(PTC)	183	1/4	LBP	134	سلفن NL7
NL6FT.2(PTC)*	156	1/5	LBP	134	
NL7FT.2(PTC)*	185	1/4	LBP	134	
NL9FT.2(PTC)*	219	1/4+	LBP	134	
NL10FT	284	1/3	LBP	134	فیلترین SC12G (پارنه و سلفن)
NL11MF	621	1/3	MBP	134	فیلترین SC12G (پارنه و سلفن)
NL7CLX	433		LBP	404	
NL8.4CLX	471		LBP	404	
NL7.3MF	393		MBP	134	
NL8.4MF	455		MBP	134	
NLY6F	187		LBP	134	سلفن NL7 - High efficiency (7% در رانندگی)
NLY7F	213		LBP	134	سلفن NL9 - High efficiency (7% در رانندگی)
NLY9FK	237		LBP	134	High efficiency (7% در رانندگی)
BD50F	72		LBP/MBP	134	
BD350GH	167		LBP/MBP	134	
GS21MLX	2200		MBP	404	
GS26CLX	1430		LBP	404	
GS34CLX	2072		LBP	404	
GS26MLX	2866		MBP	404	
GS34MLX	3726		MBP	404	

(LBP @ -33.3°C ASHRAE) زیر صفر
(MBP @ -6.7°C ASHRAE) بالای صفر

Private Picture Copyright : WWW.MBSM.PRO

Compresseur, Commercial Compressor, Disp. 11.80cc, KONOR, GPY12AF, R134a, 200-240v , 1/3 Hp, 325w, GQR60AA, GPY12AF, GP16MG, GBY16AF, GQY70AA, DH136C25B, présentoir 420L, CSIR , LBP

Category: compressor

written by www.mbsm.pro | 12 December 2021



Private Picture Copyright : WWW.MBSM.PRO

Modèle	Bloc d'alimentation	Déplacement (³ de cm)	Capacité de refroidissement (w)	Puissance nominale (w)	COP (W/W)	Type de moteur	Emballage (Pcs/palette)	1× 20 FCL (PCs)
GPY12AF	200-240V/50Hz	11.8	325	244	1.33	CSIR	80	2000

spécification

DRIV à moteur hermétique en le compresseur du type à bielle de piston. Avec démarrage par relais de type marteau et équipé d'un protecteur de surcharge.

Application

Largement utilisé dans les réfrigérateurs domestiques et commerciaux, les armoires à rideaux d'air, les vitrines, les machines à glaçons, les refroidisseurs, les déshumidificateurs, etc.

Série de compresseurs haute efficacité R134aLBP

Modèle: GPY12AF

Puissance: 1 / 3HP

Déplacement: 11,8 cm³

Capacité: 325w

COP: 1,36 W

Tension: 200-240V / 50HZ

Manière de moteur: CSIR

Application: LBP

Type de refroidissement: refroidissement par ventilateur

Hauteur: 210 mm

Poids net: 12,9 kg

Dimension: 210 * 162 * 237.2 (millimètre)

Conditions d'essai (ASHRAE)

Température d'évaporation -23,3 ° C

Température de condensation 54,4 ° C

Température de sous-refroidissement 32,2 ° C

Température d'aspiration 32,2 ° C

Température ambiante 32,2 ° C

Conversion:

1 watt = 3,41 Btu / h = 0,86 kcal / h

Compresseur konor GPY12AF par un présentoir de bière Quilmes 420L.

Modèle GPY12AF

Alimentation 200-240V / 50Hz

Cylindrée (cm³) 11,8

Capacité de refroidissement (W) 325

Puissance nominale (W) 244

COP (W / W) 1.33

Type de moteur CSIR LBP

Equivalent 1/3 MTC EMBRACO modèle FFI-12-HBK pour R134.

KONOR	Displ.	power	Motor type	V/Hz	Cooling capacity	W _{Net}	Weight	KG
GQR60AA	61/6		RSIR	220-240V/50Hz		140		9.4
GQR70AA	6.61/5		RSIR	220-240V/50Hz		165		9.4
GQR80AA	8.11/4		RSIR	220-240V/50Hz		198		9.4
GQR90AA	9.11/4		RSIR	220-240V/50Hz		220		10.1
GQY99AA	9.91/4		RSIR	220-240V/50Hz		270		10.9
GQY12AF	11.81/3		CSIR	220-240V/50Hz		325		10.56
GQY16AF	16.23/8		CSIR	220-240V/50Hz		380		12.1
GP16MG	16.25/8		CSIR	220-240V/50Hz		870		12.5
GP12MG	11.85/8		CSIR	220-240V/50Hz		656		10.9
GP12TG	11.83/8		CSIR	220-240V/50Hz		1140		11.8
GQR80TG	8.11/4		CSIR	220-240V/50Hz		730		9.8
GQR90TG	9.11/4		CSIR	220-240V/50Hz		830		10.5
GQR60TG	61/5		CSIR	220-240V/50Hz		520		9.8

KONON

GPY12AF

220-240V~50Hz

R134a



11.11.2013

KONON ELECTROMECHANICS CO., LTD 01071.908



Private Picture Copyright : WWW.MBSM.PRO

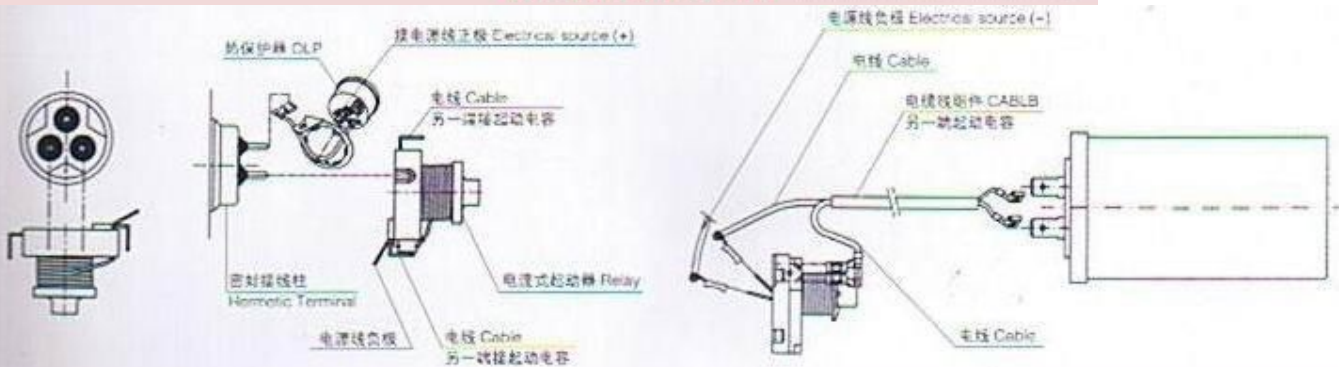

Private Picture Copyright : WWW.MBSM.PRO

R134a 系列 | R134a Range

220-240 V / 50Hz

Cliquez pour traduire les images

型号 Model	排气 容积 Displ. cm ³	电机 功率 Power HP	电机 类型 Motor Type	电压频率 Volt.-Frequency V/Hz	制冷量 Cooling Capacity w	输入功率 Input Power without RC w	with RC w	性能系数 COP without RC w/w	with RC w/w	高度 Height (A) mm	净重 Net Weight kg
GQR45AA	4.6	1/8	RSIR	220-240V/50Hz	110	96		1.15		176	8.8
GQR60AA	6.0	1/6	RSIR	220-240V/50Hz	140	116		1.21		176	9.4
GQR70AA	6.6	1/5	RSIR	220-240V/50Hz	165	136		1.21		176	9.4
GQR80AA	8.1	1/4	RSIR	220-240V/50Hz	198	166		1.19		186	9.4
GQR90AA	9.1	1/4	RSIR	220-240V/50Hz	220	184		1.19		186	10.1
GQY45AA	4.6	1/8	RSIR/RSCR	220-240V/50Hz	123	99	95	1.24	1.30	176	9.3
GQY60AA	6.0	1/6	RSIR/RSCR	220-240V/50Hz	157	115	112	1.36	1.40	176	9.4
GQY70AA	6.6	1/5	RSIR/RSCR	220-240V/50Hz	175	126	121	1.39	1.45	186	10.0
GQY80AA	8.1	1/4	RSIR/RSCR	220-240V/50Hz	222	164	158	1.35	1.41	186	10.3
GQY90AA	9.1	1/4	RSIR/RSCR	220-240V/50Hz	245	184	176	1.33	1.39	186	10.3
GQY99AA	9.9	1/4	RSIR/RSCR	220-240V/50Hz	270	203	194	1.33	1.39	199	10.9



Private Picture Copyright : WWW.MBSM.PRO

型号 Model	排气 容积 Displ. cm ³	电机 功率 Power HP	电机 类型 Motor Type	电压频率 Volt.-Frequency V/Hz	制冷量 Cooling Capacity w	输入功率 Input Power without RC w with RC w	性能系数 COP without RC w/w with RC w/w	高度 Height (A) mm	净重 Net Weight kg
GQR60TG	6.0	1/5	CSIR	200-220V/50Hz 220-230V/60Hz	520 600	260 290	2.00 2.10	176	9.8
GQR80TG	8.1	1/4	CSIR	200-220V/50Hz 220-230V/60Hz	730 800	340 380	2.15 2.10	186	10.8
GQR90TG	9.1	1/4	CSIR	200-220V/50Hz 220-230V/60Hz	830 920	370 436	2.24 2.24	186	10.8
GP12TG	11.8	3/8	CSIR	200-220V/50Hz	1140	520	2.19	199	11.8

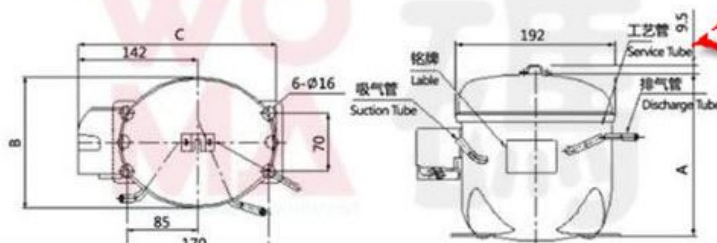

Private Picture Copyright : WWW.MBSM.PRO

R134a 系列 | R134a Range

Cliquez pour traduire les images

200-220 V / 50Hz, 220-230 V / 60Hz

展示柜专用 | For Display Cabinet

型号 Model	排气 容积 Displ. cm ³	电机 功率 Power HP	电机 类型 Motor Type	电压频率 Volt.-Frequency V/Hz	制冷量 Cooling Capacity w	输入功率 Input Power without RC w with RC w	性能系数 COP without RC w/w with RC w/w	高度 Height (A) mm	净重 Net Weight kg
GP12MG	11.8	5/8	CSIR	200-220V/50Hz 220-230V/60Hz	656 788	400 476	1.64 1.66	203	10.8
GP16MG	16.2	5/8	CSIR	200-220V/50Hz 220-230V/60Hz	870 975	560 610	1.55 1.60	212	11.2

Private Picture Copyright : WWW.MBSM.PRO

200-240V / 50Hz

上海珂纳压缩机-低背压
 Cliquez pour traduire les images

型号	制冷量 W	输入功率 W	代替型号1	代替型号2	备注
GQR60AA	140	116	华意HYE55Y63		
GQR70AA	165	136	华意HYE60YL		
GQR80AA	198	166	华意HYE69Y63		
GQR90AA	220	184	华意HYE81Y		
GQY99AA	270	203	华意HY90Y		
GPY12AF	325	244	华意HY113Y		
GPY16AF	380	292	华意HY131Y		

200-220V / 50Hz, 220-230V / 60Hz 上海珂纳压缩机-高背压

型号	制冷量 W	输入功率 W	代替型号1	代替型号2	备注
GQR90TG	830	370	华意HYE81YZ		
GP12TG	1140	520	华意HY131YZ		
GP12MG	1140	520	华意HY131YZ		
GP16MG	1430	650	华意HY153YZ		

Private Picture Copyright : WWW.MBSM.PRO

Compresseur, QD210, réfrigération,
2/3 HP, 3.2 Lra, R406A, (R12), 21CC ,
435W, pour réfrigérateur, CSIR, QD30,
QD36, QD43, QD52, QD55, QD59, QD65,
QD75, QD85, QD91, QD110, QD128,
QD142, QD168, QD180, QD210

Category: compressor

written by www.mbsm.pro | 12 December 2021



QD59 **EL MARWA**
220V~50Hz 1PH
M/HBP HSI R134a
No 7066626866 MADE IN CHINA
RoHS CE CCC



Suction tube



Private Picture Copyright : WWW.MBSM.PRO

Conditions de test

Evap. Temp.: -23,3 ° C

Cond. Temp.: 54,4 ° C

Amb. Temp.: 32,2 ° C

Aspiration. Temp .: 32,2 ° C

Temp. De sous-refroidissement: 32,2 ° C

LBP ASHRAE

Modèle: QD210

Alimentation: 220-240V / 50Hz

Cylindrée (cm³): 21,0

Capacité de refroidissement (W): 510

Puissance nominale (W): 435

Puissance nominale (HP): 2/3

COP (W / W): 1,17

Courant nominal (A): 3,1

Type de moteur: CSIR

Condensateur ($\frac{1}{4}$ F): 80 (démarrage)

Relais de démarrage: QD210

Type de refroidissement: F

Emballage (PCS / palette): 60

1- 20'FCL (PCS): 1200

Caractéristiques

1. Haute efficacité et fiabilité

2. Faible vibration

Application

LBP, armoire, congélateur, vitrine, distributeur automatique, machine à glace et machines de réfrigération moyennes et grandes.

Description rapide

Type:

Compresseur

Point d'origine:

Shanghai, China

Marque nom:

Wansheng

Certification:

CE

Service après-vente fourni:

Support en ligne

Garantie:

1 AN

After-sales Service Provided:

Engineers available to service machinery overseas

color:

black

Emballage et livraison

Unités de vente :

Article unique

Taille du paquet individuel :

80X70X75 cm

Poids brut par article :

50.000 kg

Type d'emballage :

Carton

Délai : :

Quantité(Morceaux) 1 – 80 81 – 500 >500

Durée estimée (jours) 7 11 À négocier

QD compresseur

Réfrigérants	Modèle	T-23.3 °C	Capacité	Réfrigération	Puissance d'entrée	Débit d'injection
R12/406	QD30	78	82			230
	QD36	88	86			230
	QD43	118	112			230
	QD52	138	128			230
	QD55	132	125			250
	QD59	146	137			250
	QD65	158	145			250
	QD75	176	162			250
	QD85	202	184			250
	QD91	222	192			250
	QD110	271	232			310
	QD128	306	290			310
	QD142	333	280			310
	QD168	380	330			550
	QD180	440	380			550
QD210	510	435			550	

Compresseurs frigorifiques des séries E, P

Ces compresseurs entièrement fermés sont caractéristiques d'une faible vibration, d'un faible bruit, d'une longue durée de vie et d'un rendement élevé, qui adoptent la structure du piston de bielle. Ils conviennent aux appareils de réfrigération tels que les réfrigérateurs, les glaciers, les cryostats, les vitrines et les séparateurs d'humidité, etc.

Modèle	QD45P	QD55E	QD55P	QD65E	QD75E
Déplacer (cm ³)	4,5	5.5	5.5	6,5	7,5
Capacité (W)	102	125	139	150	170
Entrée moteur (W)	107	125	135	145	162
COP (w / w)	0,95	1.0	1,03	1,03	1,05
Courant (A)	0,82	1.0	1,05	1.10	1,20
Réfrigérant	R12				
Source de courant	220V (165 i ^a 242) V 50Hz				
Charge d'huile (cm ³)	230				
Type de moteur	RSIR				
Refroidissement du compresseur	Statique				
Poids à sec (Kg)	7,8	7,8	8	8.3	8,5

Compresseurs frigorifiques série S

Ces compresseurs entièrement fermés sont caractéristiques d'une faible vibration, d'un faible bruit, d'une longue durée de vie et d'un rendement élevé, qui adoptent la structure du piston de bielle.

Modèle	QD23	QD30	QD36	QD43	QD52
Déplacer (cm ³)	2,3	3.0	3,6	4.3	5.2
Capacité (W)	50	70	78	102	122
Entrée moteur (W)	69	87	86	112	128
COP (w / w)	0,72	0,80	0,90	0,91	0,95
Courant (A)	0,62	0,65	0,68	0,88	0,98
Réfrigérant	R12				
Source de courant	220V (165 i ^a 242) V				50Hz
Charge d'huile (cm ³)	215				
Type de moteur	RSIR				
Refroidissement du compresseur	Statique				
Poids à sec (Kg)	6,35	6,65	6,85	7,5	7,5

Chlore libre iY Série Frigorifique Compresseurs iY semi-haute efficacité

Ces compresseurs entièrement fermés sont caractéristiques d'une faible vibration, d'un faible bruit, d'une longue durée de vie et d'un rendement élevé, qui adoptent la structure du piston de bielle. Ils conviennent aux appareils de réfrigération tels que les réfrigérateurs, les glacières, les cryostats, les vitrines et les séparateurs d'humidité, etc.

Modèle	QD85Y	QD91Y	QD103Y
Déplacer (cm ³)	8,5	9.1	10,3
Capacité (W)	140	155	175
Entrée moteur (W)	105	110	123
COP (w / w)	1,33	1,4	1,42
Réfrigérant	R600a		
Source de courant	220V (165 i ^a 242) V		50Hz
Charge d'huile (cm ³)	255		
Type de moteur	RSIR		
Refroidissement du compresseur	Statique		

Compresseurs frigorifiques série G

Ces compresseurs entièrement fermés sont caractéristiques d'une faible vibration, d'un faible bruit, d'une longue durée de vie et d'un rendement élevé, qui adoptent la structure du piston de bielle. Ils conviennent aux appareils de réfrigération tels que les réfrigérateurs, les glacières, les cryostats, les vitrines et les séparateurs d'humidité, etc.

Modèle	QD91G	QD110G	QD128G
Déplacer (cm ³)	9.1	11,0	12,8
Capacité (W)	240	290	350

Entrée moteur (W)	192	232	280
COP (w / w)	1,25	1,25	1,25
Courant (A)	1,40	1,60	2.0
Réfrigérant	R12		
Source de courant	220V (165 i ^a 242) V 50Hz		
Charge d'huile (cm ³)	255	310	
Type de moteur	RSIR		
Refroidissement du compresseur	Refroidissement par ventilateur		
Poids à sec (Kg)	10,6	11	11.2

Compresseurs frigorifiques de la série Q

Ces compresseurs entièrement fermés sont caractéristiques d'une faible vibration, d'un faible bruit, d'une longue durée de vie et d'un rendement élevé, qui adoptent la structure du piston de bielle. Ils conviennent aux appareils de réfrigération tels que les réfrigérateurs, les glacières, les cryostats, les vitrines et les séparateurs d'humidité, etc.

Modèle	QD91	QD110	QD128	QD128A
Déplacer (cm ³)	9.1	11,0	12,8	12,8
Capacité (W)	210	260	292	325
Entrée moteur (W)	192	232	260	280
COP (w / w)	1,09	1.12	1.12	1,16
Courant (A)	1,40	1,60	2.0	2.0
Réfrigérant	R12			
Source de courant	220V (165 i ^a 242) V 50Hz			
Charge d'huile (cm ³)	255	310		
Type de moteur	RSIR			
Refroidissement du compresseur	Refroidissement par ventilateur			
Poids à sec (Kg)	10,6	11	11.2	11.2

Compresseurs frigorifiques série SC

Ils conviennent aux appareils de réfrigération tels que les réfrigérateurs, les glacières, les cryostats, les vitrines et les séparateurs d'humidité, etc.

Modèle	Refrig.	Déplacer	Capacité	Entrée moteur	Actuel	FLIC	Charge d'huile	Type de moteur	alimentation électrique	Refroidissement du compresseur	Capacitance	Poids à sec (kg)
QD168	R12	16,8 cm ³	380 W	330 W	2,3 A	1,15	550 cm ³	CSIR	220V50Hz		80 Ì F iÀ 10%	13 kg
QD180	R12	17,8 cm ³	429 W	380w	2,8 A	1.13	550 cm ³	CSIR	220V50Hz		80 Ì F iÀ 10%	13,5 kg
QD210	R12	21cm ³	495 W	430w	3.2A	1,15	550 cm ³	CSIR	220V50Hz	Fam refroidissement	Fonctionnement £ ° 10 Ì F Démarrage £ ° 80 Ì F iÀ 10%	13,5 kg



Private Picture Copyright : WWW.MBSM.PRO

Mbsm_dot_pro_private_PDF_QD210Télécharger

Compresseur, 1/3 HP, Danfoss, SECOP,
tropicalisé, NL10FT, R134a, 220 –
240/1/50, CSIR – RSIR, 105G6829
SECOP, 105G6869 SECOP, 105G6140
SECOP, 105G6147 SECOP, 105G6141 SECOP

Category: compressor

written by www.mbsm.pro | 12 December 2021



Private Picture Copyright : WWW.MBSM.PRO

- Marque : DANFOSS SECOP
- Modèle : NL10FT
- CYLINDRÉE (CM³) 10,1
- FLUIDER-134a
- APPLICATION LBP
- PLAGES D'APPLICATION -35/-10
- PUISSANCE (W) 455
- PUISSANCE FRIGORIFIQUE (TK+40°C) -10/455 -20/281 -30/158 -35/113
- TENSION (V) 240/1/50
- DÉMARRAGE SIR
- I.MAX (A) 1,88
- Ø ASPIRATION 8,2
- Ø REFOULEMENT 6,2
- DIMENSIONS (MM) 205x166x203

Alimentation du compresseur [V/Ph/Hz]	220-240/1/50
Applications	LBP
Charge en fluide frigorigène [kg] [Max]	0.4 kg
Code de configuration	Simple
Couleur	Noir
Courant d'appel HST [A]	10.4 A
Courant d'appel LST [A]	13.6 A

Description	NL10FT
Diamètre de raccordement à l'aspiration [mm]	8.2 mm
Diamètre du raccord au refoulement [mm]	6.2 mm
Diamètre du raccordement du traitement [mm]	6.2 mm
Désignation du modèle	Compresseur
Faible valeur de plage de tension à 50 Hz [V]	198 V
Faible valeur de plage de tension à 60 Hz [V]	0 V
Faible valeur de tension nominale à 50 Hz [V]	220 V
Faible valeur de tension nominale à 60 Hz [V]	0 V
Fluides	R134a
Format d'emballage	Emballage industriel
Fréquence [Hz]	50
Hauteur de la base [mm]	197 mm
Hauteur totale [mm]	203 mm
Injection de liquide	No
Longueur [mm]	252 mm
LRA HST 60Hz [A]	10.4 A
LRA HST [A]	10.4 A
LRA LST [A]	9.2 A
Matériel du raccord au process	Acier cuivré
Matériel du raccord d'aspiration	Acier cuivré
Matériel du raccord de refoulement	Acier cuivré
Niveau d'énergie de l'application	Tropical
Nombre de phases (compresseur)	1
Nombre de phases (ventilateur)	1
Notes concernant le raccord de refoulement	Capuchon en aluminium
Notes concernant le raccordement au process	Capuchon en aluminium
Notes concernant le raccordement à l'aspiration	Capuchon en aluminium
N° de modèle	NL10FT
Oil type	POE
Phase	1
Profondeur [mm]	166 mm
Quantité d'huile [cm ³]	300 cm ³
Quantité par emballage	80
raccord de refoulement équerre [°]	35 °
raccord d'aspiration équerre [°]	15 °
Raccordement de process équerre	25 °
RLA	1.80 A
Régulation de la puissance	Vitesse fixe
Résistance de l'enroulement auxiliaire (enroulement de démarrage) pour compresseurs monophasés [ohm]	14.7 Ohm
Résistance de l'enroulement auxiliaire (enroulement de démarrage) pour compresseurs monophasés à pistons [ohm]	14.7 Ohm
Résistance de l'enroulement principal pour compresseurs monophasés [Ohm]	8.2 Ohm
Technique de la marque	Compresseur à pistons

Technologie	Piston
Température d'enroulement max. continue [°C] [Max]	125 °C
Température de l'enroulement à court terme [°C] [Max]	135 °C
Tension 50 Hz [V]	220 V
Tension 50 Hz [V] [max.]	240 V
Type	NL
Type de moteur	CSIR RSIR
Type de socle	Petit UE
Utilisation de tronçon	Réfrigération LT
Valeur élevée de plage de tension à 50 Hz [V]	264 V
Valeur élevée de plage de tension à 60 Hz [V]	0 V
Valeur élevée de tension nominale à 50 Hz [V]	240 V
Valeur élevée de tension nominale à 60 Hz [V]	0 V
Vitesse de rotation à 50 Hz [rpm]	2900 rpm
Vitesse de rotation à 60 Hz [rpm]	0 rpm
Volume balayé [cm³]	10.09 cm³
Volume de gaz libre [cm³]	2360 cm³
Économiseur	No

Mbsm_dot_pro_private_PDF_nl10ft_105g6829_r134a_220v_50hz_04-2019_desd406p202Télécharger



ASPERA, COMPRESSEUR, 1 / 3HP++ (Big), NE6181E, CSIR, HMBP, R22, 220-240V

Category: compressor

written by www.mbsm.pro | 12 December 2021



Private Picture Copyright : WWW.MBSM.PRO



Private Picture Copyright : WWW.MBSM.PRO

NE6181E 1 / 3HP / R22

- **Détails techniques**

puissance 1/3 CV, cylindrée 7,28 cm³
220 / 240V 50Hz

- LIGNE LIQUIDE (DIAMÈTRE) : 1/4
- LIGNE D'ASPIRATION (DIAMÈTRE) : 5/16
- BRÈVE DESCRIPTION



Private Picture Copyright : WWW.MBSM.PRO

Mbsm_dot_pro_private_PDF_NE6181ETélécharger

GQR16TG, light, commercial,
refrigeration, compressor ,1 / 2+ HP,
220V/50Hz, CSIR, capacitor:08UF,
R134A, Middle/Hight Back Pressure

Category: compressor

written by www.mbsm.pro | 12 December 2021



GQR16TG, light, commercial, refrigeration, compressor ,1 / 2+ HP, 220V/50Hz, CSIR, capacitor:80UF, R134A